

MagicDrill for Large Dia (over 60mm)

- MagicDrill for large diameters (over $\varnothing 59$) are available as Custom Orders.
(Ask your regional sales staff for details such as cutting dia. / shank type, etc.)
- Cartridge-type drill (DRZ-CR type) for diameters over $\varnothing 60$ mm.

DRZ-CR

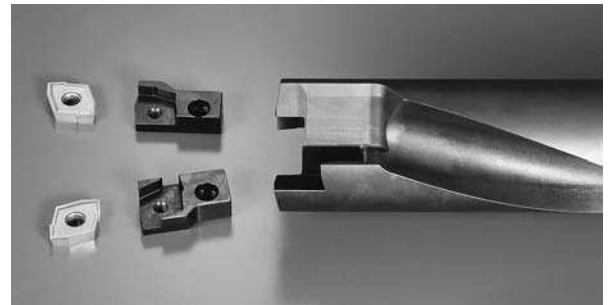
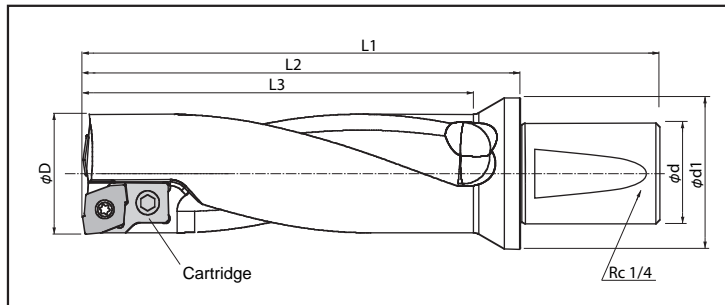

Toolholder Dimensions

Description	Std.	No. of Insert	Dimension (mm)						Max. Offset (Radial) (mm)	Spare Parts				Applicable Inserts ● K39	
			øD	L1	L2	L3	ød	ød1		Cartridge		Clamp Screw	Wrench		
										for Outer Edge	for Inner Edge				
S50-DRZ60180-20CR	<input type="checkbox"/>	2	60	286	217	195	50	75	+3.0	DR20CR-OUT (1 pc)	DR20CR-IN (1 pc)	SB-60120TR	DT-25	ZCMT200608	
-DRZ65195-20CR	<input type="checkbox"/>	2	65	296	227	206									+1.5
-DRZ70210-20CR	<input type="checkbox"/>	2	70	308	239	220									+0.2
-DRZ75225-12CR	<input type="checkbox"/>	4	75	330	261	225	50	80	Offset N.A.	DR12CR-OUT (2 pc)	DR12CR-IN (2 pc)	SB-5085TR	DT-20	ZCMT12T306 ZCMT12T304SP	
-DRZ80240-12CR	<input type="checkbox"/>	4	80	340	271	240									

For recommended cutting conditions, see page ● K51

Cartridge

Spare Parts			
Cartridge		Cartridge Clamp Screw	Wrench
for Outer Edge	for Inner Edge		
DR20CR-OUT	DR20CR-IN	HH6x12	LW-5
DR12CR-OUT	DR12CR-IN	HH4x12	LW-3

Drill diameter and Coolant

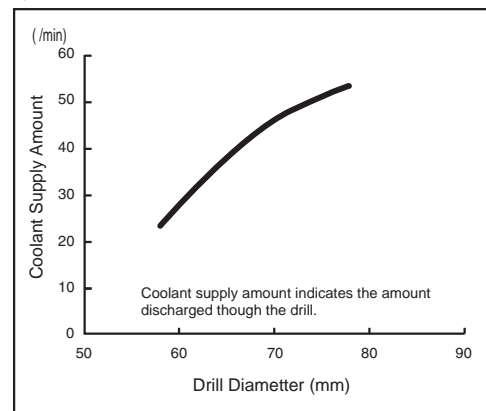

All DRZ-CR drills are made to order

● : Std. Item : Check Availability