

MagicDrill® DRZ

DRZ (Cutting Depth: 2xD)

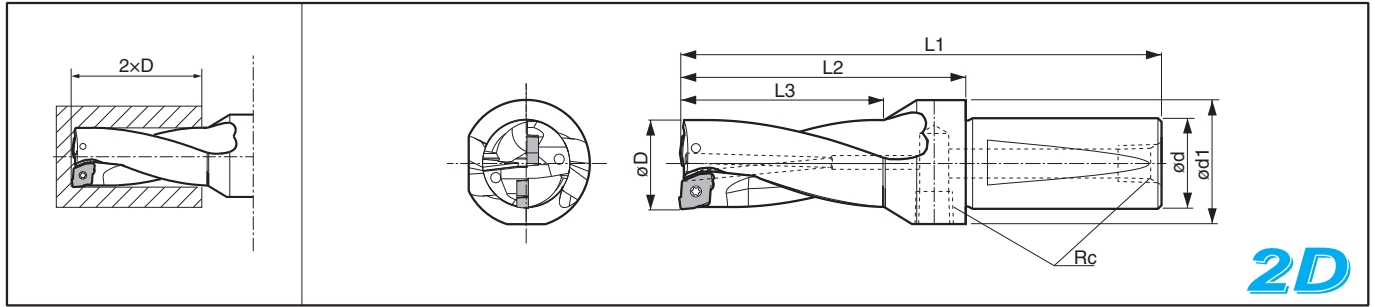

Toolholder Dimensions

| Description | Std. No. of Insert | Dimension (mm) | | | | | | | Max. Offset (Radial) (mm) | Spare Parts | | | Applicable Inserts ● K39 |
|-----------------------|-----------------------|----------------|-----|----|----|----|-----|-------|---------------------------------|-------------|--------------------|------|--|
| | | øD | L1 | L2 | L3 | ød | ød1 | Rc | | Clamp Screw | Wrench FT DT | Plug | |
| S20-DRZ1326-05 | ● | 13 | 95 | 52 | 26 | | | | +0.5 | | | | ZCMT050203 ZCMT050203SP ZCMT050203SU |
| -DRZ135270-05 | ● | 13.5 | 95 | 52 | 27 | | | | +0.5 | | | | |
| -DRZ1428-05 | ● | 14 | 98 | 55 | 28 | | | | +0.5 | | | | |
| -DRZ145290-05 | ● | 14.5 | 98 | 55 | 29 | 20 | 27 | Rc1/8 | +0.5 | SB-2045TR | FT-6 | GP-1 | |
| -DRZ1530-05 | ● | 15 | 100 | 57 | 30 | | | | +0.5 | | | | |
| -DRZ155310-05 | ● | 15.5 | 100 | 57 | 31 | | | | +0.5 | | | | |
| S25-DRZ1632-06 | ● | 16 | 115 | 61 | 32 | | | | +1.1 | | | | ZCMT06T204 ZCMT06T204SP ZCMT06T204SU |
| -DRZ165330-06 | ● | 16.5 | 115 | 61 | 33 | | | | +0.9 | | | | |
| -DRZ1734-06 | ● | 17 | 116 | 62 | 34 | | | | +0.8 | | | | |
| -DRZ175350-06 | ● | 17.5 | 116 | 62 | 35 | | | | +0.7 | | | | |
| -DRZ1836-06 | ● | 18 | 118 | 64 | 36 | | | | +0.6 | | | | |
| -DRZ185370-06 | ● | 18.5 | 118 | 64 | 37 | 25 | 32 | Rc1/8 | +0.6 | SB-2260TR | DT-7 | GP-1 | |
| -DRZ1938-06 | ● | 19 | 120 | 66 | 38 | | | | +0.5 | | | | |
| -DRZ195390-06 | ● | 19.5 | 120 | 66 | 39 | | | | +0.5 | | | | |
| -DRZ2040-06 | ● | 20 | 123 | 69 | 40 | | | | +0.5 | | | | |
| -DRZ205410-06 | ● | 20.5 | 125 | 71 | 41 | | | | +0.3 | | | | |
| -DRZ2142-06 | ● | 21 | 125 | 71 | 42 | | | | +0.2 | | | | |
| -DRZ215430-08 | ● | 21.5 | 128 | 74 | 43 | | | | +1.8 | | | | |
| -DRZ2244-08 | ● | 22 | 128 | 74 | 44 | | 33 | | +1.6 | | | | |
| -DRZ225450-08 | ● | 22.5 | 128 | 74 | 45 | | | | +1.4 | | | | |
| -DRZ2346-08 | ● | 23 | 130 | 76 | 46 | | | | +1.3 | | | | |
| -DRZ235470-08 | ● | 23.5 | 130 | 76 | 47 | | | | +1.2 | | | | |
| -DRZ2448-08 | ● | 24 | 131 | 77 | 48 | 25 | | Rc1/8 | +1.1 | SB-2570TR | DT-8 | GP-1 | |
| -DRZ245490-08 | ● | 24.5 | 131 | 77 | 49 | | | | +0.9 | | | | |
| -DRZ2550-08 | ● | 25 | 133 | 79 | 50 | | | | +0.8 | | | | |
| -DRZ255510-08 | ● | 25.5 | 133 | 79 | 51 | | 35 | | +0.7 | | | | |
| -DRZ2652-08 | ● | 26 | 135 | 81 | 52 | | | | +0.6 | | | | |
| -DRZ265530-08 | ● | 26.5 | 135 | 81 | 53 | | | | +0.5 | | | | |
| S32-DRZ2754-10 | ● | 27 | 149 | 90 | 54 | | | | +2.5 | | | | ZCMT10T304 ZCMT10T304SP |
| -DRZ275550-10 | ● | 27.5 | 149 | 90 | 55 | | | | +2.3 | | | | |
| -DRZ2856-10 | ● | 28 | 151 | 92 | 56 | | 42 | | +2.2 | | | | |
| -DRZ285570-10 | ● | 28.5 | 151 | 92 | 57 | | | | +2.1 | | | | |
| -DRZ2958-10 | ● | 29 | 153 | 94 | 58 | | | | +2.0 | | | | |
| -DRZ295590-10 | ● | 29.5 | 153 | 94 | 59 | 32 | | Rc1/4 | +1.8 | SB-4085TR | DT-15 | GP-2 | |
| -DRZ3060-10 | ● | 30 | 154 | 95 | 60 | | | | +1.7 | | | | |
| -DRZ305610-10 | ● | 30.5 | 154 | 95 | 61 | | | | +1.5 | | | | |
| -DRZ3162-10 | ● | 31 | 155 | 96 | 62 | | 45 | | +1.5 | | | | |
| -DRZ315630-10 | ● | 31.5 | 155 | 96 | 63 | | | | +1.3 | | | | |
| -DRZ3264-10 | ● | 32 | 158 | 99 | 64 | | | | +1.2 | | | | |
| -DRZ325650-10 | ● | 32.5 | 158 | 99 | 65 | | | | +1.0 | | | | |

· When offset machining, reduce feed rate to 0.08mm/rev. or less.

For recommended cutting conditions, see page **K51**

● : Std. Item □ : Check Availability

