

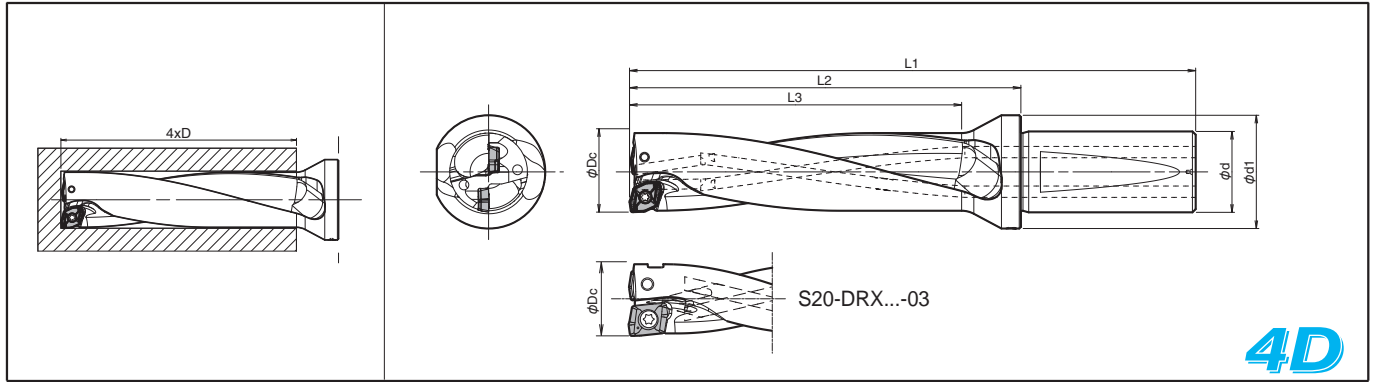

# MagicDrill® DRX

**DRX** (Cutting Depth:4xD)

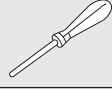

● Toolholder Dimensions

Description	Std.	No. of Insert	Dimension (mm)						Max. Offset (Radial) (mm)	Spare Parts		Applicable Inserts ➔ K24								
			øDc	L1	L2	L3	ød	ød1		Clamp Screw 	Wrench 									
<b>S20</b> -DRX120M-4-03	●	2	12	112	69	48	20	27	+0.5	SB-2042TRG	DTM-6	Outer edge ZXMT030203 ○○-E Inner Edge ZXMT030203GM-I								
-DRX125M-4-03	●		12.5	114	71	50							+0.4							
-DRX130M-4-03	●		13	116	73	52							+0.3							
-DRX135M-4-04	●	2	13.5	118	75	54	20	27	+0.5	SB-2042TRG	DTM-6	ZXMT040203 ○○								
-DRX140M-4-04	●		14	120	77	56							+0.4							
-DRX145M-4-04	●		14.5	122	79	58							+0.3							
-DRX150M-4-04	●		15	124	81	60							+0.2							
<b>S25</b> -DRX155M-4-05	●	2	15.5	140	86	62	25	32	+0.8	SB-2045TR	DTM-6	ZXMT05T203 ○○								
-DRX160M-4-05	●		16	142	87	64							+0.7							
-DRX165M-4-05	●		16.5	144	90	66							+0.5							
-DRX170M-4-05	●		17	146	91	68							+0.4							
-DRX175M-4-05	●		17.5	148	94	70							+0.3							
-DRX180M-4-05	●		18	150	95	72							+0.2							
-DRX185M-4-06	●	2	18.5	149	95	74	25	32	+0.9	SB-2250TR	DTM-7	ZXMT06T204 ○○								
-DRX190M-4-06	●		19	151	97	76							+0.8							
-DRX195M-4-06	●		19.5	153	99	78							+0.7							
-DRX200M-4-06	●		20	155	101	80							+0.5							
-DRX205M-4-06	●		20.5	157	103	82							+0.4							
-DRX210M-4-06	●		21	159	105	84							+0.3							
-DRX215M-4-06	●		21.5	161	107	86							+0.2							
-DRX220M-4-07	●		2	22	163	108							88	25	35	+1.2	SB-2570TR	DTM-8	ZXMT070305 ○○	
-DRX225M-4-07	●			22.5	165	111							90							+1.0
-DRX230M-4-07	●			23	167	112							92							+0.9
-DRX235M-4-07	●	23.5		169	115	94	+0.8													
-DRX240M-4-07	●	24		171	116	96	+0.7													
-DRX245M-4-07	●	24.5		173	119	98	+0.5													
-DRX250M-4-07	●	25		175	120	100	+0.4													
-DRX255M-4-07	●	25.5		177	123	102	+0.3													
-DRX260M-4-07	●	26		179	124	104	+0.2													
<b>S32</b> -DRX270M-4-09	●	2		27	190	130	108	32	42	+1.6	SB-3080TR	DTM-10	ZXMT09T306 ○○							
-DRX280M-4-09	●		28	194	134	112	+1.3													
-DRX290M-4-09	●		29	198	138	116	+1.1													
-DRX300M-4-09	●		30	202	142	120	+0.8													
-DRX310M-4-09	●		31	206	146	124	+0.6													
<b>S40</b> -DRX320M-4-11	●	2	32	223	154	128	40	50	+2.2	SB-4085TR	DTM-15	ZXMT11T306 ○○								
-DRX330M-4-11	●		33	227	158	132							+1.9							
-DRX340M-4-11	●		34	231	162	136							+1.7							
-DRX350M-4-11	●		35	235	166	140							+1.4							
-DRX360M-4-11	●		36	239	170	144							+1.2							
-DRX370M-4-11	●		37	243	174	148							+0.9							
-DRX380M-4-11	●		38	247	178	152							+0.7							

• When offset machining, reduce feed rate to 0.06mm/rev. or less.  
• See K35 for Adjustable Sleeve (SHE type).

For recommended cutting conditions, see page ➔ K34

For trouble shooting, see page ➔ K33

● : Std. Item

