

Covers a variety of workpiece materials with new chipbreaker

● New chipbreaker features

◆ Wider chipbreaker (outer edge)

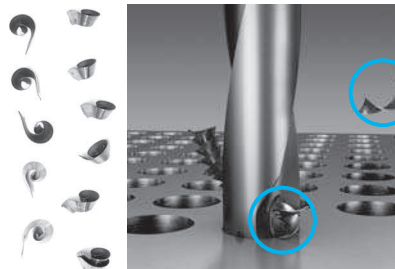

small chips for better evacuation

◆ Flat chipbreaker (inner edge)

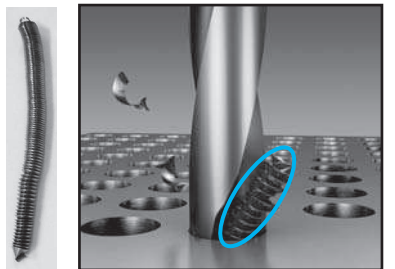

ideal continuous chips

◆ Sigmoid cutting edge (outer edge)

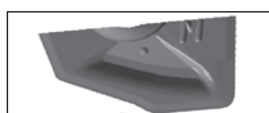

sigmoid outer cutting edge
↓
sharp cutting

Vc=120m/min, f=0.1mm/rev., H=15mm, ø20-3D, WET, C55 (S55C)

DRX

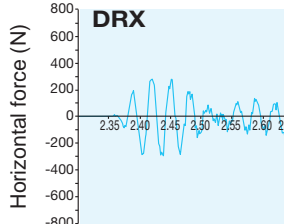

Competitor G

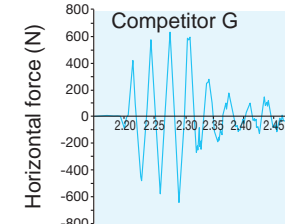

Lowered impact force at the start
↓
Reduces sudden breakage

Cutting force comparison of outer edge at the start of drilling

● Chipbreaker selection

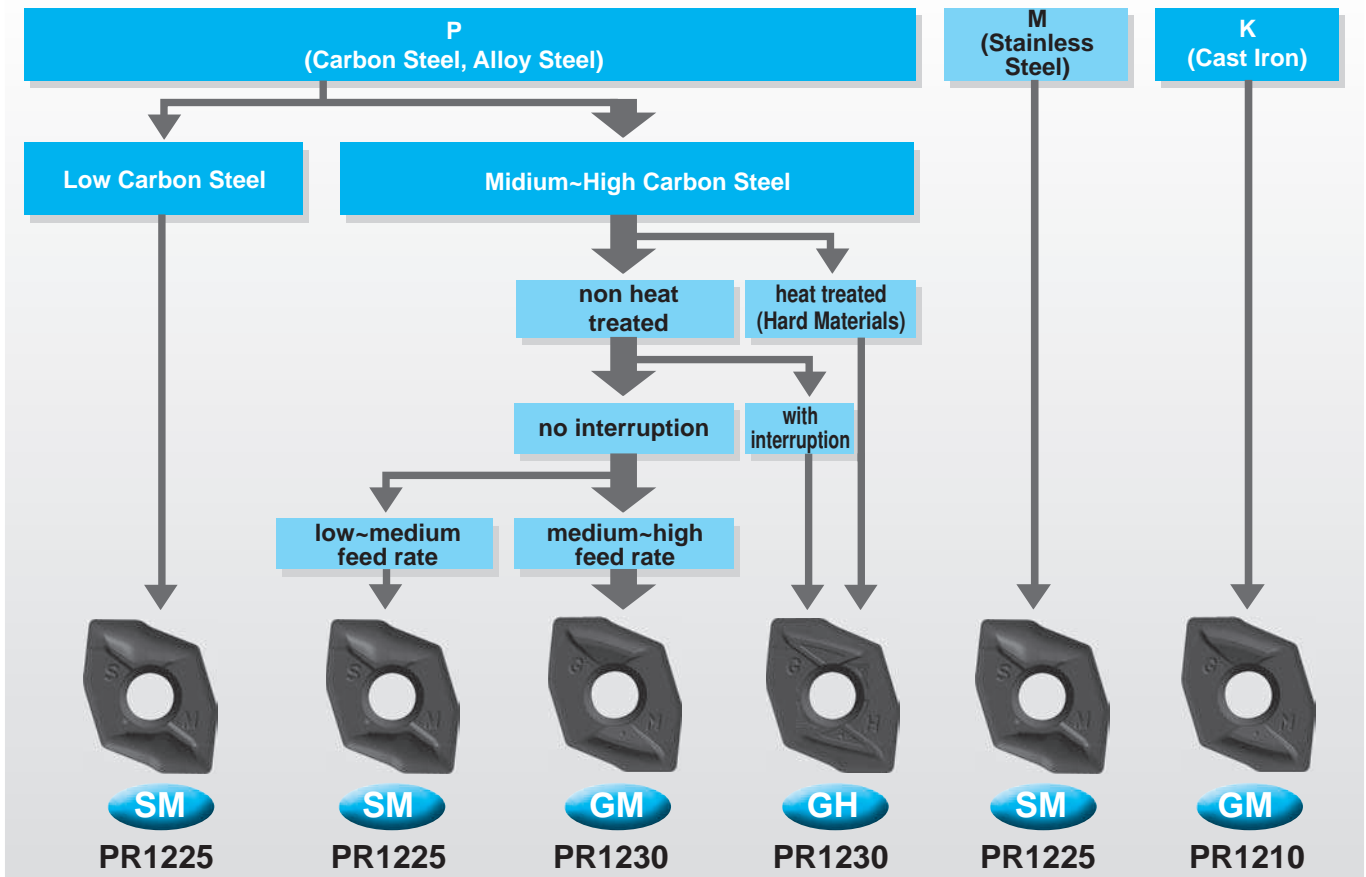

K
Drilling