

External Threading Toolholders [TTX Insert]

KTTX

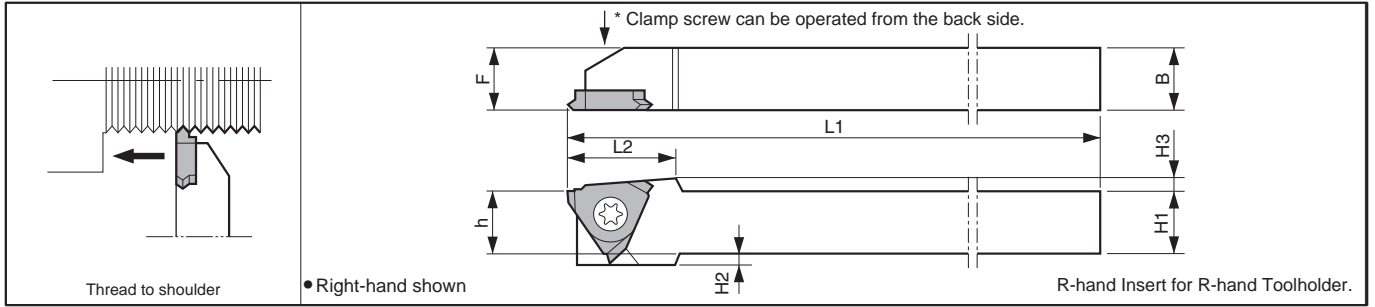

Toolholder Dimensions

Description	Std.	Dimension (mm)							Spare Parts				
		H1-h	H2	H3	B	L1	L2	F	Clamp Screw	Wrench			
KTTXR 1010JX-16F	●	10	2		10			10	SB-4070TRW	FT-8			
	●	12		2.5	12	120	17.6	12					
	●	16			16			16					
KTTXR 1212F -16F	●	12		2.5	12	85	17.6	12	SB-4070TRW	FT-8			
	●	20			20	125		20					

S...KTTX (External Sleeve Holder)

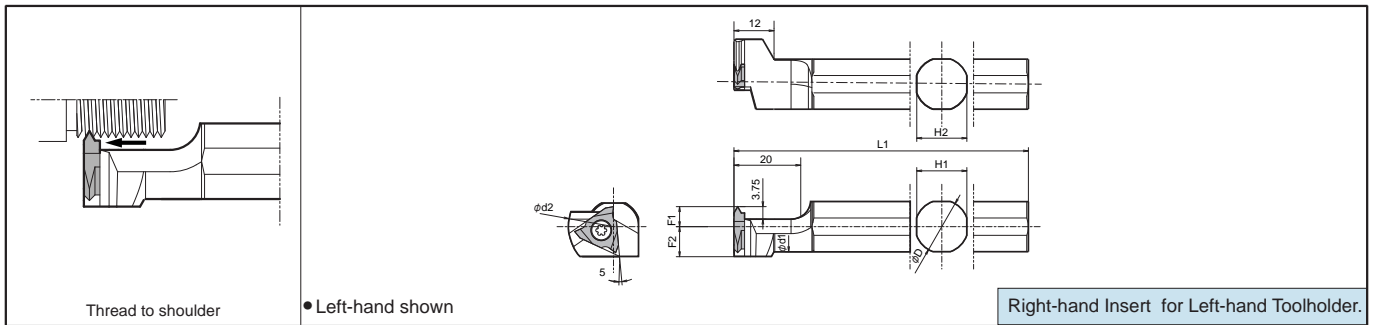

Toolholder Dimensions

Description	Std.	Dimension (mm)							Spare Parts				
		øD	L1	F1	F2	ød1	ød2	H1-H2	Clamp Screw	Wrench			
S12F-KTTXL16	●	12.0	80			11.0		11	SB-4070TRW	FT-8			
S14H-KTTXL16	●	14.0	100			13.0		13					
S15F-KTTXL16	●	15.875	85		9.0	14.6	27	15					
S16F-KTTXL16	●	16.0											
S19G-KTTXL16	●	19.05	90					17					
S19K-KTTXL16	●		120	10.5	17.6								
S20G-KTTXL16	●	20.0	90					18					
S20K-KTTXL16	●		120	11.0	18.6								
S25.0H-KTTXL16	●	25.0	100	10.0	14.0	23.6	32	23					
S25K-KTTXL16	●	25.4	120										