

Face Grooving Toolholders [GVF Insert]

GFVS

This toolholder can machine various face grooving diameters by replacing the Blade.

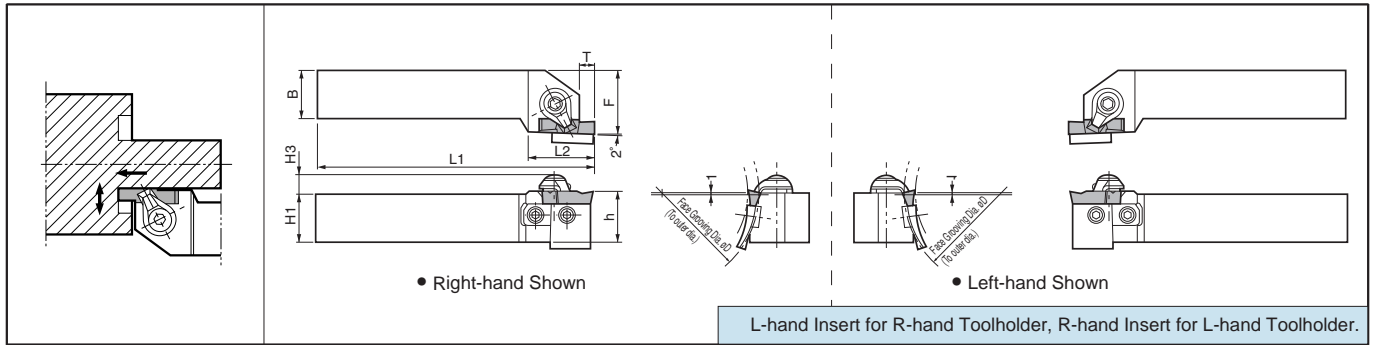

GFVT

This toolholder can machine various face grooving diameters by replacing the Blade.

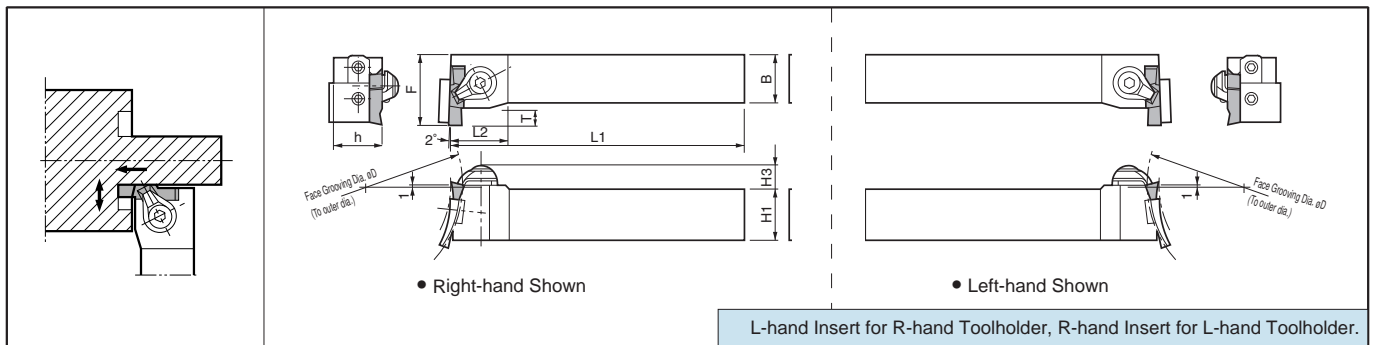

Selection of Toolholder & Insert

GFVS type				GFVT type			
Toolholder	R-hand	Insert	L-hand	Toolholder	R-hand	Insert	L-hand

Combination of Base-Holder & Blade

Base-Holder (Stamped below)	Std.		Blade Description	Toolholder (Integrated Tool)	Example of installation (GFVS)	How to refer to the face grooving toolholder and blade
	R	L				
GFVS ^{R/L} .2020K-HB GFVT ^{R/L} .2020K-HB	●	●	SF ^{R/L} -351B	GFVS ^{R/L} .2020K -351B		Q: Though "GFVSR2525M-HC" is marked on the face grooving holder, the size of cutting dia. is unknown. How could it be found out? A: Take off the blade. Description of the blade is listed on the back of the blade. Using the description, check the description of the holder in the catalog. If "SFR-1001C" is integrated to "GFVSR2525M-HC", the description of the holder is "GFVSR2525M-1001C".
	●	●	-352B	GFVT ^{R/L} .2020K -352B		
			-501B	-501B		
			-502B	-502B		
			-701B	-701B		
			-702B	-702B		
GFVS ^{R/L} .2525M-HB GFVT ^{R/L} .2525M-HB	●	●	SF ^{R/L} -351B	GFVS ^{R/L} .2525M -351B		
	●	●	-352B	GFVT ^{R/L} .2525M -352B		
			-501B	-501B		
			-502B	-502B		
			-701B	-701B		
			-702B	-702B		
GFVS ^{R/L} .2525M-HC GFVT ^{R/L} .2525M-HC	●	●	SF ^{R/L} -501C	GFVS ^{R/L} .2525M -501C		
	●	●	-502C	GFVT ^{R/L} .2525M -502C		
			-701C	-701C		
			-702C	-702C		
			-1001C	-1001C		
			-1002C	-1002C		
		-1501C	-1501C			
		-1502C	-1502C			

- R-hand Blade for R-hand Toolholder, L-hand Blade for L-hand Toolholder.
- Installation of GFVT type is also pursuing example of installation of GFVS type.

● : Std. Item □ : Check Availability