

# Internal Grooving Toolholders

## KIGM-V

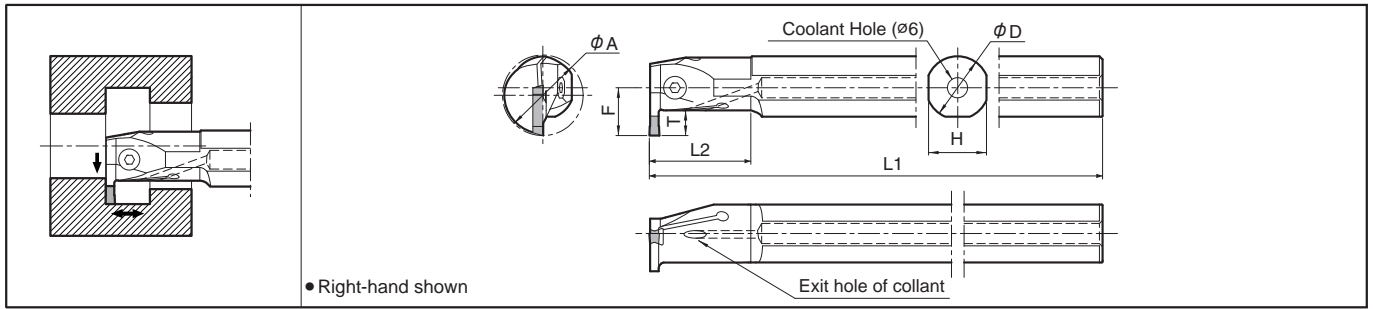

### Toolholder Dimensions

Description	Std.		Min. Cutting Dia.	Dimension (mm)								Width (mm)		Spare Parts					
	R	L		φA	φD	H	L1	L2	F	T	MIN.	MAX.	Screw		Wrench				
	<b>KIGM<sup>R/L</sup></b>																		
<b>2016B-3V</b>	●	●	20	16	15	150	25	11.5	5.5					3.0	3.0	GS-50	-	LW-3	-
<b>2520B-3V</b>	●	●	25	20	18	180	32	14.5	6.0										
<b>3225B-3V</b>	●	●	32	25	23	200	40	19	8.0							-	SB-5TR	-	LTW-20
<b>3225B-4V</b>	●	●	32	25	23	200	40	19	8.5					4.0	5.0	-	SB-5TR	-	LTW-20
<b>4032B-4V</b>	●	●	40	32	29	220	50	23.5	11.0										

\* Dimension T shows available grooving depth.

### Applicable Inserts

Description	L	H
<b>GMM3015...V</b> ○	15.5	4.3
<b>GMM4020...V</b> ○	20	
<b>GMM5020...V</b> ○		

	P	M	K	N	S	H	Classification of usage													
	Carbon Steel / Alloy Steel	Stainless Steel	Cast Iron	Non-ferrous Metals	Titanium Alloy	Hard materials (under 40HRC)														
						Hard materials (over 40HRC)														

Insert	Description	(Previous Description)	Dimension (mm)			Cermet TN90	CVD Coated Carbide CR9025	PVD Coated Carbide PR915	PVD Coated Carbide PR930	PVD Coated Carbide PR905	Carbide KW10	Applicable Toolholder
			W	rc	M							
				<b>GMM 3015-040V</b>	<b>GMM 3015-04V</b>							
	<b>4020-040V</b>	<b>4020-04V</b>	4.0	0.4	3.3	●	●	●	●	●	<b>KIGM<sup>R/L</sup></b> <b>3225B-4V</b>	
	<b>5020-080V</b>	<b>5020-08V</b>	5.0	0.8	4.2	●	●	●	●	●	<b>4032B-4V</b>	
	<b>GMM 3015-150VR</b>	<b>GMM 3015-15VR</b>	3.0	1.5	2.3	●	●		●	●	<b>KIGM<sup>R/L</sup></b> <b>2016B-3V</b> <b>2520B-3V</b> <b>3225B-3V</b>	
	<b>4020-200VR</b>	<b>4020-20VR</b>	4.0	2.0	3.3	●		●	●	●	<b>KIGM<sup>R/L</sup></b> <b>3225B-4V</b>	
	<b>5020-250VR</b>	<b>5020-25VR</b>	5.0	2.5	4.2	●		●	●	●	<b>4032B-4V</b>	

\* It is not recommended to use this for KIGM-V Internal Grooving Toolholders against GMM...V / GMM...VR for which the front relief angle is 18°, because the relief angle of the insert used for GMM4020-04 toolholder is 10°.

For recommended cutting conditions, see page **G93**

Inserts are sold in 10 piece boxes.

● : Std. Item □ : Check Availability R : Std. Item (R-hand Only) L : Std. Item (L-hand Only)