

Internal Small Diameter Grooving Toolholders [GV Insert]

для заказа - kyocera@kyocera-tools.ru www.kyocera-tools.ru

GIV

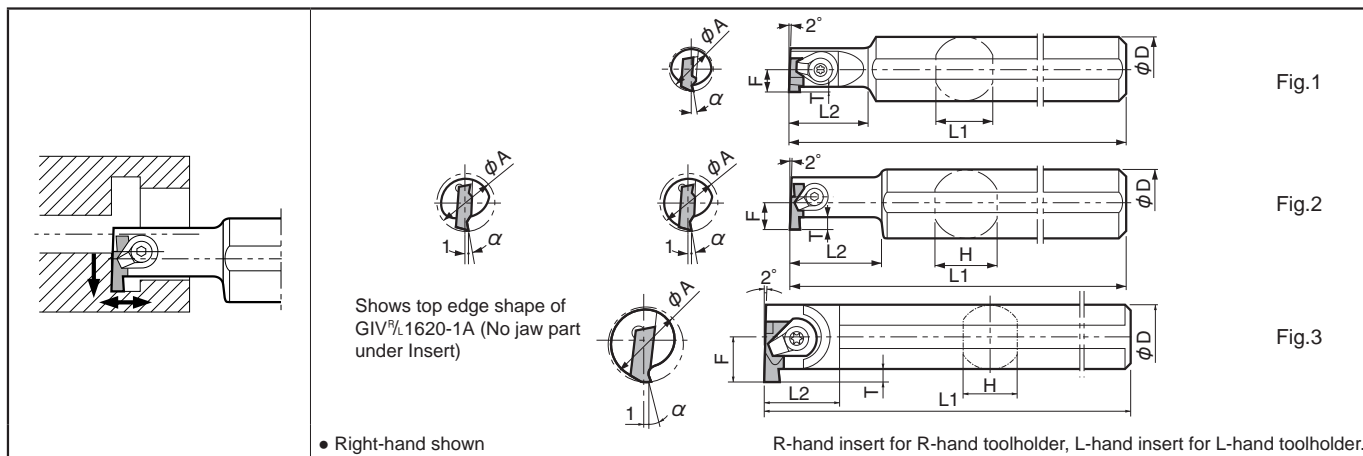

GIV-E Excellent Bar

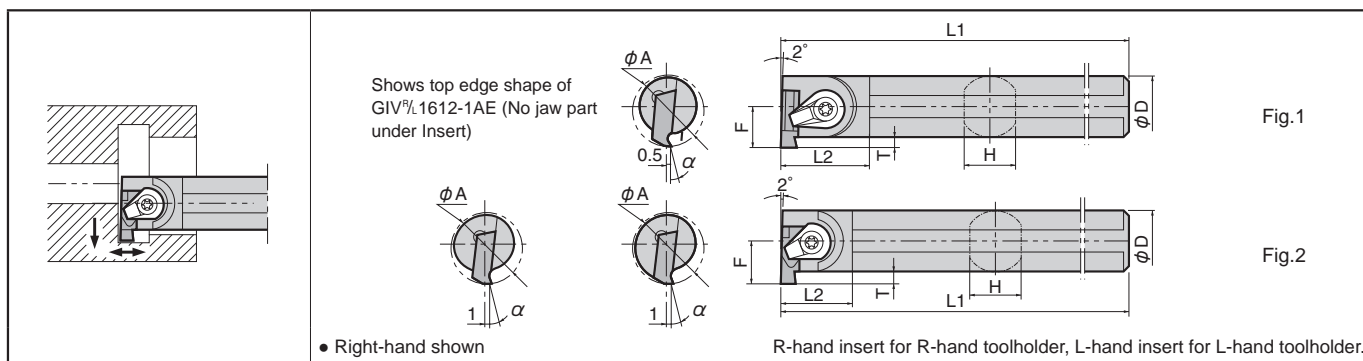

GIV-W Carbide Shank Bar

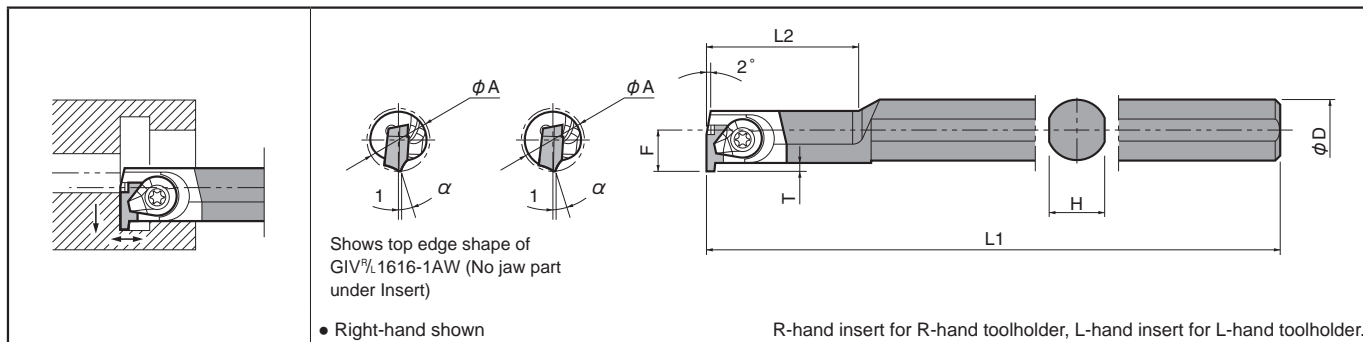

Applicable Insert & Rake Angle (α) after Installment of Insert

| Toolholder | Description G54 | | Rake Angle (α) | |
|-----------------------------|-------------------------------|-------------------------------|-------------------------|------------------------------------|
| | General Grooving (Square) | Full-R Grooving (Round) | TC40 | TN90, TC60 PR630, PR930 KW10 |
| GIV [®] /L...1SS | GV [®] /L100SS~300SS | - | 10° | 15° |
| GIV [®] /L...1S | GV [®] /L100S~340S | - | 10° | 15° |
| GIV [®] /L...1SE | GV [®] /L100S~340S | - | 3° | 8° |
| GIV [®] /L...1A(□) | GV [®] /L100A~340A | GV [®] /L100AR~150AR | 3° | 8° |
| GIV [®] /L...1B(□) | GV [®] /L145B~250B | GV [®] /L100BR | 4° | 9° |
| GIV [®] /L...2B(□) | GV [®] /L280B~400B | GV [®] /L150BR | | |
| GIV [®] /L...1C(□) | GV [®] /L280C~340C | - | 5° | 10° |
| GIV [®] /L...2C(□) | GV [®] /L400C~500C | - | | |