

Summary of Face Grooving

Micro Dia. Face Grooving $\phi 6\sim$

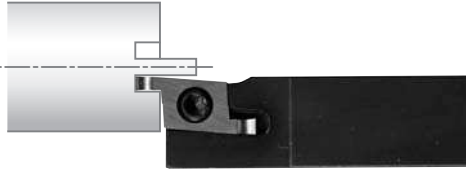

Type	STW
Min. Face Groove Dia.	$\phi 6$
Width (mm)	0.5~2.0
Grooving Depth (mm)	1.0~3.0
Ref. Page	G66

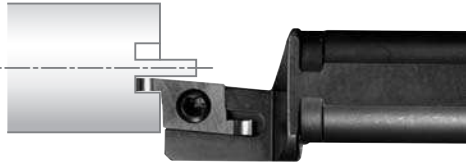

Type	S..-STW
Min. Face Groove Dia.	$\phi 6$
Width (mm)	0.5~2.0
Grooving Depth (mm)	1.0~3.0
Ref. Page	G66



Type	STWS
Min. Face Groove Dia.	$\phi 6$
Width (mm)	0.5~2.0
Grooving Depth (mm)	1.0~3.0
Ref. Page	G67



G

Grooving

Small Dia. Face Grooving $\phi 8\sim$

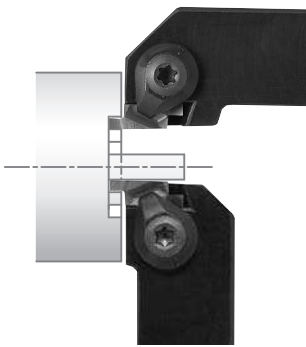

Type	GFVS-AA
Min. Face Groove Dia.	$\phi 8$
Width (mm)	1.0~3.0
Grooving Depth (mm)	2.2
Ref. Page	G76

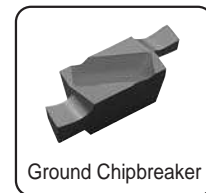

Type	GFVT-AA
Min. Face Groove Dia.	$\phi 8$
Width (mm)	1.0~3.0
Grooving Depth (mm)	2.2
Ref. Page	G76

Small Dia. Face Grooving $\phi 8\sim$

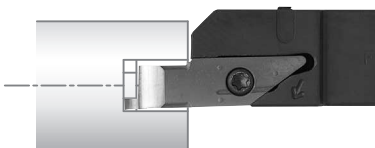

Type	VNFG
Min. Face Groove Dia.	$\phi 8$
Width (mm)	1.0~3.0
Grooving Depth (mm)	2.0~3.0
Ref. Page	G64

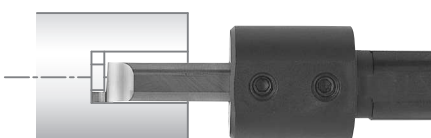
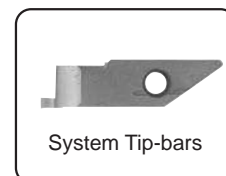

Type	HPFG
Min. Face Groove Dia.	$\phi 8$
Width (mm)	1.0~3.0
Grooving Depth (mm)	2.0~3.0
Ref. Page	G65

