

● Deep Grooving (G57, G60)

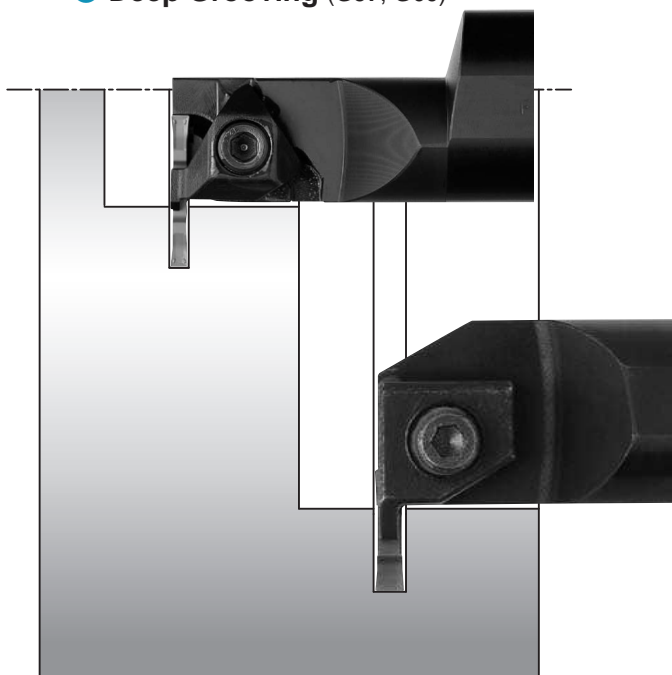

Type	KGIA
Min.Bore Dia.	ø32~ø66
Width (mm)	3.0~5.0
Grooving Depth (mm)	10~15
Ref. Page	G60

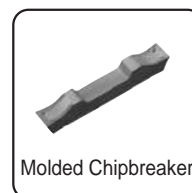

Type	KIGH
Min.Bore Dia.	ø45~ø65
Width (mm)	4.0~8.0
Grooving Depth (mm)	12
Ref. Page	G57

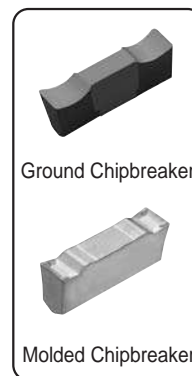

■ Internal Grooving & Longitudinal turning ø20~ (G58, G59)

CERACUT Plunge & Turn

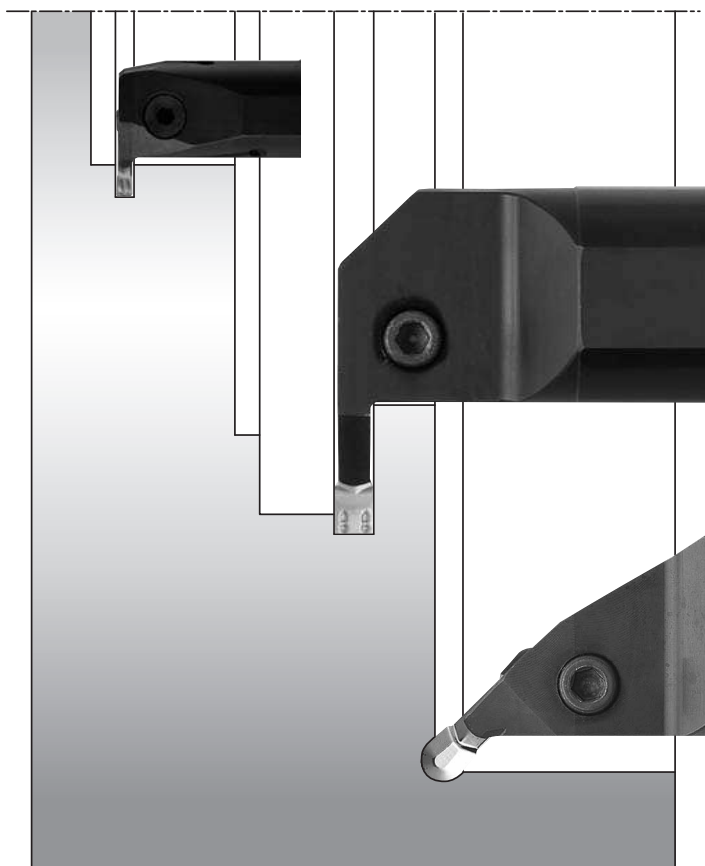

Type	KIGM-V
Min.Bore Dia.	ø20~ø40
Width (mm)	3.0~5.0
Grooving Depth (mm)	5.5~11.0
Ref. Page	G58

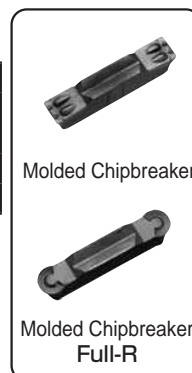

Type	KIGM-8
Min.Bore Dia.	ø65
Width (mm)	8.0
Grooving Depth (mm)	20
Ref. Page	G59



Type	KIGMU-8
Min.Bore Dia.	ø65
Width (mm)	8.0
Grooving Depth (mm)	2.2
Ref. Page	G59

G



Grooving

