

Summary of External Grooving

External Grooving & Longitudinal turning (G32-G39)

CERACUT Plunge & Turn

Type	KGMM
Width (mm)	3.0~5.0
Grooving Depth (mm)	4.8
Ref. Page	G38

Type	KGMS
Width (mm)	3.0~5.0
Grooving Depth (mm)	4.8
Ref. Page	G38

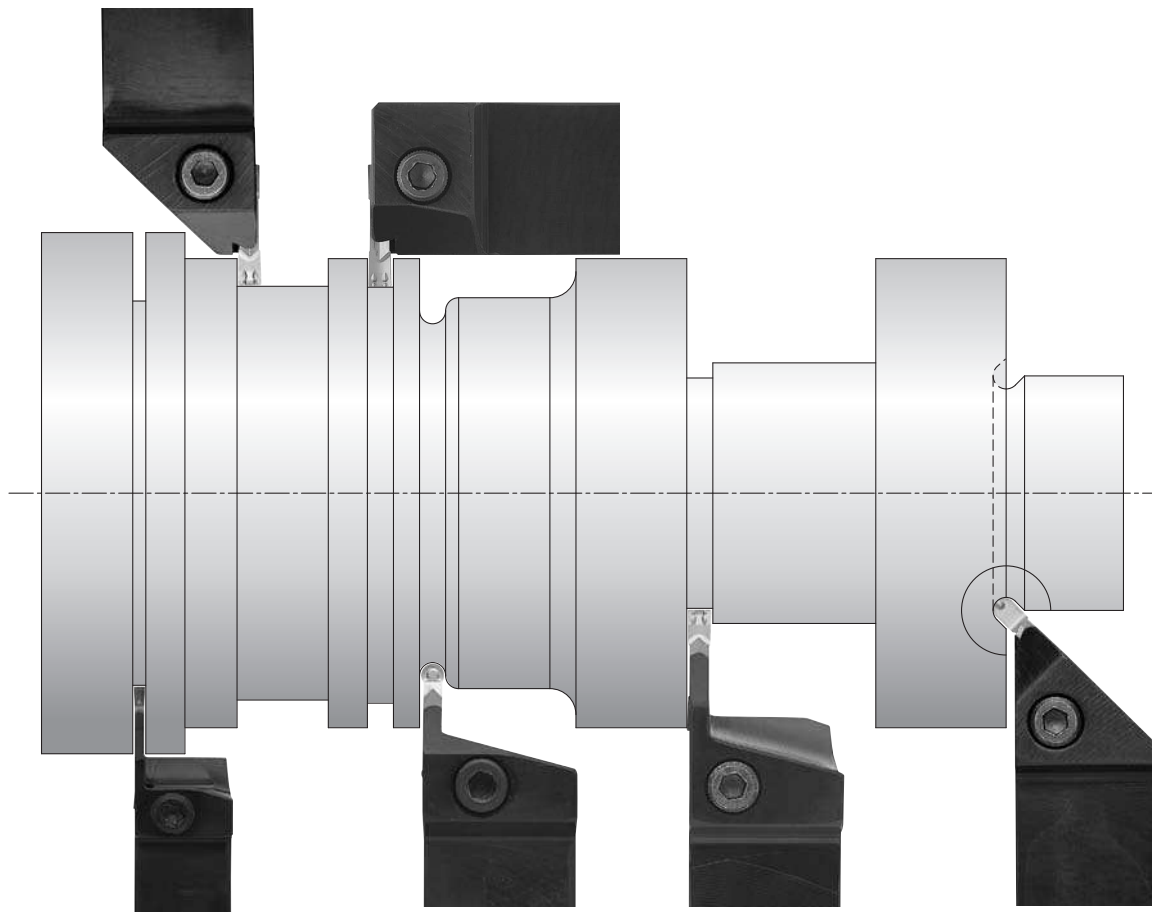
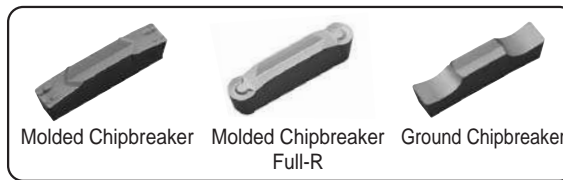

Type	KGM
Width (mm)	1.5~4.0
Grooving Depth (mm)	5~16
Ref. Page	G36

Type	KGM
Width (mm)	3.0~8.0
Grooving Depth (mm)	9~25
Ref. Page	G36

Type	KGM-T
Width (mm)	2.0~6.0
Grooving Depth (mm)	17~30
Ref. Page	G37

Type	KGMU
Width (mm)	3.0~5.0
Grooving Depth (mm)	3.5~4.5
Ref. Page	G39

