

# Boring Bar [TN Negative Insert]

## S...PTUN (Boring)

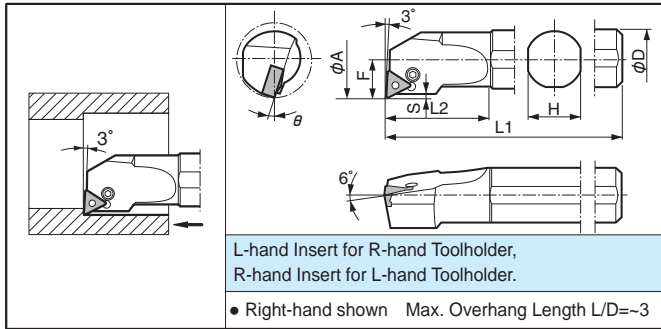

## A...PTUN11 Twin-Hole Bar (Boring: with Coolant Hole)

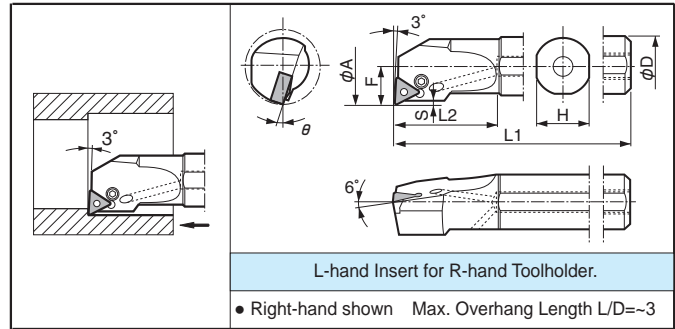

### Toolholder Dimensions

Description	(Previous Description)	Std.		Dimension (mm)							θ	Standard Corner-R (r)	Spare Parts					
		R	L	Min. Bore Dia. φA	φD	H	L1	L2	F	S			Lever	Lock Screw	Shim	Shim Pin LSP	Punch	Wrench
S16M-PTUN <sup>R/L</sup> 11-20	PTUN <sup>R/L</sup> 2016B-11	●	●	20	16	15	150	34	11	0.3	18°	0.8	LL-03TN	LS-03SN	-	P-03S	-	FH-2.5
S20Q-PTUN <sup>R/L</sup> 11-25	2520B-11	●	●	25	20	19	180	37	13.2	0.2	17°	0.8	LL-03TN	LS-03SN	-	P-03S	-	FH-2.5
S25R-PTUN <sup>R/L</sup> 11-32	3225B-11	●	●	32	25	24	200	42	15.7	0.3	16°	0.8	LL-03TN	LS-03SN	-	P-03S	-	FH-2.5
S25R-PTUN <sup>R/L</sup> 16-30	-	●	●	30	25	24	200	42	15.5	1.5	13°	0.8	LL-03SN	LS-03SN	-	P-03S	-	FH-2.5
S32S-PTUN <sup>R/L</sup> 16-40	-	●	●	40	32	30	250	50	22	2.0	13°	0.8	LL-1N	LS-1N	LT-32N *LT-32N-20	LSP-1	PC-1	FH-2.5
S40T-PTUN <sup>R/L</sup> 16-50	-	●	●	50	40	37	300	60	27	1.8	11°	0.8	LL-1N	LS-1N	LT-32N *LT-32N-20	LSP-1	PC-1	FH-2.5
A16M-PTUN <sup>R/L</sup> 11-20	PTUN <sup>R/L</sup> 2016B-11H	●	●	20	16	15	150	34	11	0.3	18°	0.8	LL-03TN	LS-03SN	-	P-03S	-	FH-2.5
A20Q-PTUN <sup>R/L</sup> 11-25	2520B-11H	●	●	25	20	19	180	37	13.2	0.2	17°	0.8	LL-03TN	LS-03SN	-	P-03S	-	FH-2.5
A25R-PTUN <sup>R/L</sup> 11-32	3225B-11H	●	●	32	25	24	200	42	15.7	0.3	16°	0.8	LL-03TN	LS-03SN	-	P-03S	-	FH-2.5

\* When using insert with corner R = 1.6mm or larger, purchase and use shim with \* mark separately to prevent interference between workpiece and shim.

### Applicable Inserts

Applications	Finishing	Finishing-Medium	Finishing-Medium	Finishing-Medium	Medium-Roughing	Medium-Roughing	Medium-Roughing	Medium-Roughing / High Feed Rate	Medium-Roughing / High Feed Rate	Roughing
Ref. Page	B30	B30	B30	B30	B30	B30	B30	B31	B31	B31
Insert	GP	HQ	CQ	TK	GS	PS	HS/CS	PT	GT	Standard
Toolholder										
Applications	One side / Roughing High Feed Rate	Finishing	Medium-Roughing	Medium-Roughing / Low Cutting Resistance type	Soft Steel Finishing	Soft Steel / Medium cutting	Soft Steel / Roughing	Stainless Finishing	Stainless Medium to Roughing	Stainless Medium to Roughing
Ref. Page	B31	B34	B34	B34	B31	B31	B31	B32	B32	B32
Insert	PX	<sup>R/L</sup> -S	<sup>R/L</sup> -□	<sup>R/L</sup> -25R	XP (-T)	XQ	XS	MQ	MS	TK
Toolholder										
Applications	Stainless Medium to Roughing	Cast Iron	Cast Iron	Cast Iron	Cast Iron	Cast Iron	Non-ferrous Metals	Non-ferrous Metals	Non-ferrous Metals	Hard Materials
Ref. Page	B32	B33	B33	B33	B33	B90	B33	B33	C17	C7
Insert	<sup>R/L</sup> -ST	C	ZS	GC	Without Chipbreaker	Ceramic	AH	<sup>R/L</sup> -A3	PCD	CBN
Toolholder										
Applications	Stainless Medium to Roughing	Cast Iron	Cast Iron	Cast Iron	Cast Iron	Cast Iron	Non-ferrous Metals	Non-ferrous Metals	Non-ferrous Metals	Hard Materials
Ref. Page	B32	B33	B33	B33	B33	B90	B33	B33	C17	C7
Insert	<sup>R/L</sup> -ST	C	ZS	GC	Without Chipbreaker	Ceramic	AH	<sup>R/L</sup> -A3	PCD	CBN
Toolholder										
Applications	Stainless Medium to Roughing	Cast Iron	Cast Iron	Cast Iron	Cast Iron	Cast Iron	Non-ferrous Metals	Non-ferrous Metals	Non-ferrous Metals	Hard Materials
Ref. Page	B32	B33	B33	B33	B33	B90	B33	B33	C17	C7
Insert	<sup>R/L</sup> -ST	C	ZS	GC	Without Chipbreaker	Ceramic	AH	<sup>R/L</sup> -A3	PCD	CBN
Toolholder										
Applications	Stainless Medium to Roughing	Cast Iron	Cast Iron	Cast Iron	Cast Iron	Cast Iron	Non-ferrous Metals	Non-ferrous Metals	Non-ferrous Metals	Hard Materials
Ref. Page	B32	B33	B33	B33	B33	B90	B33	B33	C17	C7
Insert	<sup>R/L</sup> -ST	C	ZS	GC	Without Chipbreaker	Ceramic	AH	<sup>R/L</sup> -A3	PCD	CBN
Toolholder										
Applications	Stainless Medium to Roughing	Cast Iron	Cast Iron	Cast Iron	Cast Iron	Cast Iron	Non-ferrous Metals	Non-ferrous Metals	Non-ferrous Metals	Hard Materials
Ref. Page	B32	B33	B33	B33	B33	B90	B33	B33	C17	C7
Insert	<sup>R/L</sup> -ST	C	ZS	GC	Without Chipbreaker	Ceramic	AH	<sup>R/L</sup> -A3	PCD	CBN
Toolholder										
Applications	Stainless Medium to Roughing	Cast Iron	Cast Iron	Cast Iron	Cast Iron	Cast Iron	Non-ferrous Metals	Non-ferrous Metals	Non-ferrous Metals	Hard Materials
Ref. Page	B32	B33	B33	B33	B33	B90	B33	B33	C17	C7
Insert	<sup>R/L</sup> -ST	C	ZS	GC	Without Chipbreaker	Ceramic	AH	<sup>R/L</sup> -A3	PCD	CBN
Toolholder										
Applications	Stainless Medium to Roughing	Cast Iron	Cast Iron	Cast Iron	Cast Iron	Cast Iron	Non-ferrous Metals	Non-ferrous Metals	Non-ferrous Metals	Hard Materials
Ref. Page	B32	B33	B33	B33	B33	B90	B33	B33	C17	C7
Insert	<sup>R/L</sup> -ST	C	ZS	GC	Without Chipbreaker	Ceramic	AH	<sup>R/L</sup> -A3	PCD	CBN
Toolholder										
Applications	Stainless Medium to Roughing	Cast Iron	Cast Iron	Cast Iron	Cast Iron	Cast Iron	Non-ferrous Metals	Non-ferrous Metals	Non-ferrous Metals	Hard Materials
Ref. Page	B32	B33	B33	B33	B33	B90	B33	B33	C17	C7
Insert	<sup>R/L</sup> -ST	C	ZS	GC	Without Chipbreaker	Ceramic	AH	<sup>R/L</sup> -A3	PCD	CBN
Toolholder										
Applications	Stainless Medium to Roughing	Cast Iron	Cast Iron	Cast Iron	Cast Iron	Cast Iron	Non-ferrous Metals	Non-ferrous Metals	Non-ferrous Metals	Hard Materials
Ref. Page	B32	B33	B33	B33	B33	B90	B33	B33	C17	C7
Insert	<sup>R/L</sup> -ST	C	ZS	GC	Without Chipbreaker	Ceramic	AH	<sup>R/L</sup> -A3	PCD	CBN
Toolholder										
Applications	Stainless Medium to Roughing	Cast Iron	Cast Iron	Cast Iron	Cast Iron	Cast Iron	Non-ferrous Metals	Non-ferrous Metals	Non-ferrous Metals	Hard Materials
Ref. Page	B32	B33	B33	B33	B33	B90	B33	B33	C17	C7
Insert	<sup>R/L</sup> -ST	C	ZS	GC	Without Chipbreaker	Ceramic	AH	<sup>R/L</sup> -A3	PCD	CBN
Toolholder										
Applications	Stainless Medium to Roughing	Cast Iron	Cast Iron	Cast Iron	Cast Iron	Cast Iron	Non-ferrous Metals	Non-ferrous Metals	Non-ferrous Metals	Hard Materials
Ref. Page	B32	B33	B33	B33	B33	B90	B33	B33	C17	C7
Insert	<sup>R/L</sup> -ST	C	ZS	GC	Without Chipbreaker	Ceramic	AH	<sup>R/L</sup> -A3	PCD	CBN
Toolholder										
Applications	Stainless Medium to Roughing	Cast Iron	Cast Iron	Cast Iron	Cast Iron	Cast Iron	Non-ferrous Metals	Non-ferrous Metals	Non-ferrous Metals	Hard Materials
Ref. Page	B32	B33	B33	B33	B33	B90	B33	B33	C17	C7
Insert	<sup>R/L</sup> -ST	C	ZS	GC	Without Chipbreaker	Ceramic	AH	<sup>R/L</sup> -A3	PCD	CBN
Toolholder										
Applications	Stainless Medium to Roughing	Cast Iron	Cast Iron	Cast Iron	Cast Iron	Cast Iron	Non-ferrous Metals	Non-ferrous Metals	Non-ferrous Metals	Hard Materials
Ref. Page	B32	B33	B33	B33	B33	B90	B33	B33	C17	C7
Insert	<sup>R/L</sup> -ST	C	ZS	GC	Without Chipbreaker	Ceramic	AH	<sup>R/L</sup> -A3	PCD	CBN
Toolholder										
Applications	Stainless Medium to Roughing	Cast Iron	Cast Iron	Cast Iron	Cast Iron	Cast Iron	Non-ferrous Metals	Non-ferrous Metals	Non-ferrous Metals	Hard Materials
Ref. Page	B32	B33	B33	B33	B33	B90	B33	B33	C17	C7
Insert	<sup>R/L</sup> -ST	C	ZS	GC	Without Chipbreaker	Ceramic	AH	<sup>R/L</sup> -A3	PCD	CBN
Toolholder										
Applications	Stainless Medium to Roughing	Cast Iron	Cast Iron	Cast Iron	Cast Iron	Cast Iron	Non-ferrous Metals	Non-ferrous Metals	Non-ferrous Metals	Hard Materials
Ref. Page	B32	B33	B33	B33	B33	B90	B33	B33	C17	C7
Insert	<sup>R/L</sup> -ST	C	ZS	GC	Without Chipbreaker	Ceramic	AH	<sup>R/L</sup> -A3	PCD	CBN
Toolholder										
Applications	Stainless Medium to Roughing	Cast Iron	Cast Iron	Cast Iron	Cast Iron	Cast Iron	Non-ferrous Metals	Non-ferrous Metals	Non-ferrous Metals	Hard Materials
Ref. Page	B32	B33	B33	B33	B33	B90	B33	B33	C17	C7
Insert	<sup>R/L</sup> -ST	C	ZS	GC	Without Chipbreaker	Ceramic	AH	<sup>R/L</sup> -A3	PCD	CBN
Toolholder										
Applications	Stainless Medium to Roughing	Cast Iron	Cast Iron	Cast Iron	Cast Iron	Cast Iron	Non-ferrous Metals	Non-ferrous Metals	Non-ferrous Metals	Hard Materials
Ref. Page	B32	B33	B33	B33	B33	B90	B33	B33	C17	C7
Insert	<sup>R/L</sup> -ST	C	ZS	GC	Without Chipbreaker	Ceramic	AH	<sup>R/L</sup> -A3	PCD	CBN
Toolholder										
Applications	Stainless Medium to Roughing	Cast Iron	Cast Iron	Cast Iron	Cast Iron	Cast Iron	Non-ferrous Metals	Non-ferrous Metals	Non-ferrous Metals	Hard Materials
Ref. Page	B32	B33	B33	B33	B33	B90	B33	B33	C17	C7
Insert	<sup>R/L</sup> -ST	C	ZS	GC	Without Chipbreaker	Ceramic	AH	<sup>R/L</sup> -A3	PCD	CBN
Toolholder										
Applications	Stainless Medium to Roughing	Cast Iron	Cast Iron	Cast Iron	Cast Iron	Cast Iron	Non-ferrous Metals	Non-ferrous Metals	Non-ferrous Metals	Hard Materials
Ref. Page	B32	B33	B33	B33	B33	B90	B33	B33	C17	C7
Insert	<sup>R/L</sup> -ST	C	ZS	GC	Without Chipbreaker	Ceramic	AH	<sup>R/L</sup> -A3	PCD	CBN
Toolholder										
Applications	Stainless Medium to Roughing	Cast Iron	Cast Iron	Cast Iron	Cast Iron	Cast Iron	Non-ferrous Metals	Non-ferrous Metals	Non-ferrous Metals	Hard Materials
Ref. Page	B32	B33	B33	B33	B33	B90	B33	B33	C17	C7
Insert	<sup>R/L</sup> -ST	C	ZS	GC	Without Chipbreaker	Ceramic	AH	<sup>R/L</sup> -A3	PCD	CBN
Toolholder										