

# Boring Bar [YP Insert]

## S...SYXP-E Excellent Bar (Boring / Internal Facing / Copying)

Max. Overhang Length L/D=5

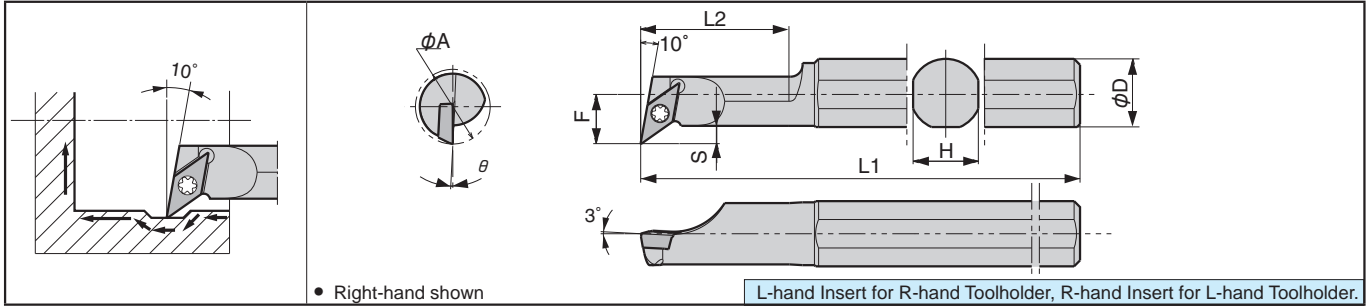

### Toolholder Dimensions

Description	(Previous Description)	Std.		Min. Bore Dia.	Dimension (mm)							θ	Standard Corner-R (r)	Spare Parts	
		R	L		φA	φD	H	L1	L2	F	S			Clamp Screw	Wrench
<b>S12M-SYXP<sup>R/L</sup>06-12E</b>	-	<input type="checkbox"/>	<input type="checkbox"/>	12	12	11	150	25	8.3	3	3°	0.2	SB-2040TR	FT-6	
<b>S16Q-SYXP<sup>R/L</sup>06-16E</b>		<input type="checkbox"/>	<input type="checkbox"/>	16	16	15	180	30	10						

### Applicable Inserts

Applications	Finishing	Low Feed												
Ref. Page	<b>B80</b>	<b>B80</b>												
Insert	<sup>R/L</sup> -F	<sup>F</sup> <sup>R/L</sup> -U												
Toolholder														
...-SYXP <sup>R/L</sup> 06-...	YPGT0602..	YPGT0602..												

For recommended cutting conditions, see page [F82-F83](#)

● : Std. Item    □ : Check Availability



Boring