

# Boring Bar [WB □□ / WP □□ Insert]

## S...SWUP(B)-E Excellent Bar (Boring)

Max. Overhang Length L/D=--5

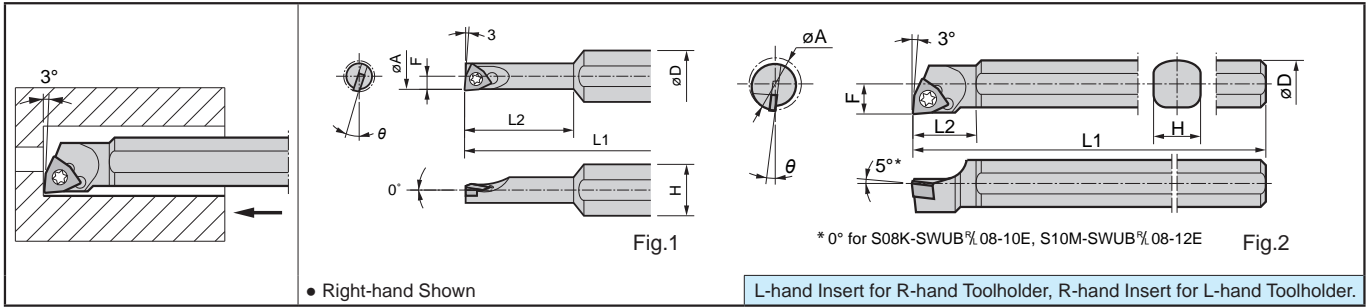

## S...SWUB Steel Bar (Boring)

Max. Overhang Length L/D=--3

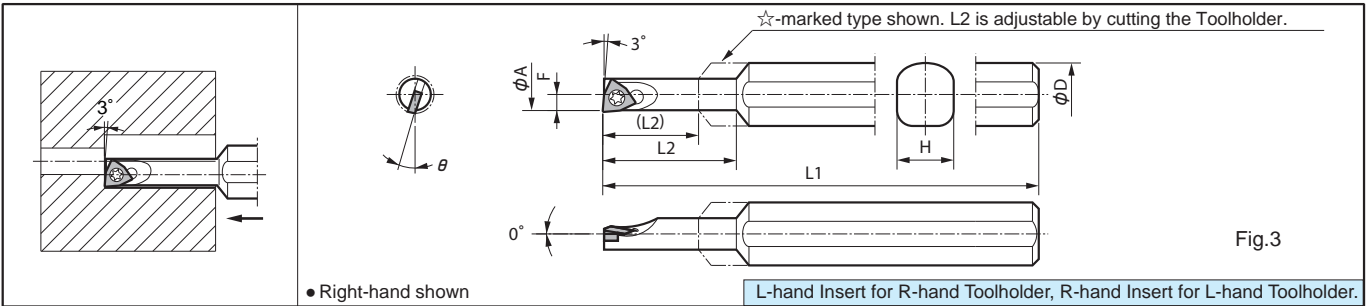

## C...SWUP (B) Carbide Shank Bar (Boring)

Max. Overhang Length L/D=--7

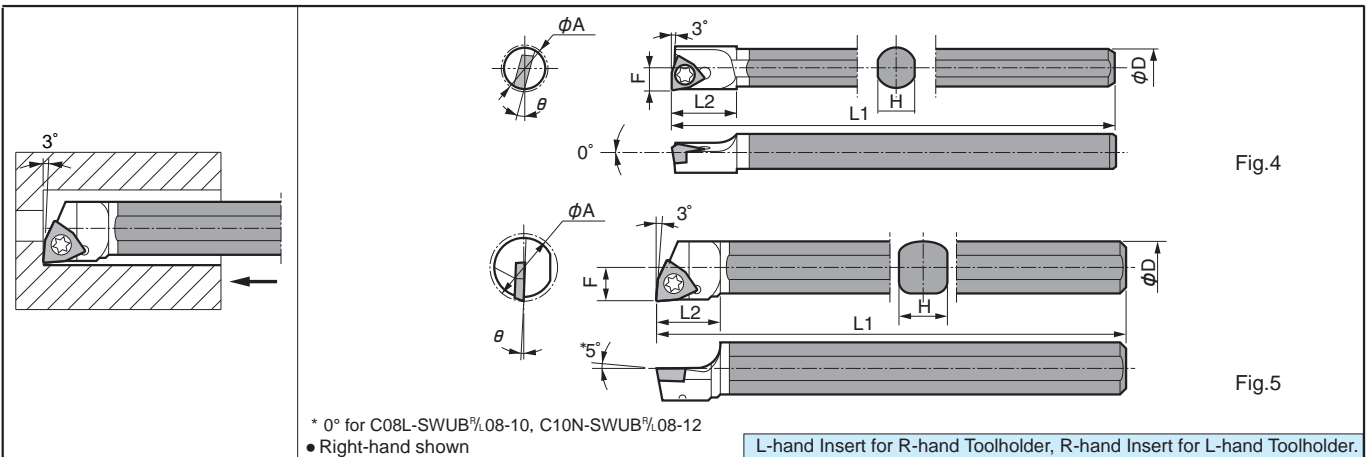

F

Boring