

Boring Bar [CP Insert]

S...SCLP-E Excellent Bar (Boring / Internal Facing)

Max. Overhang Length L/D≈-5

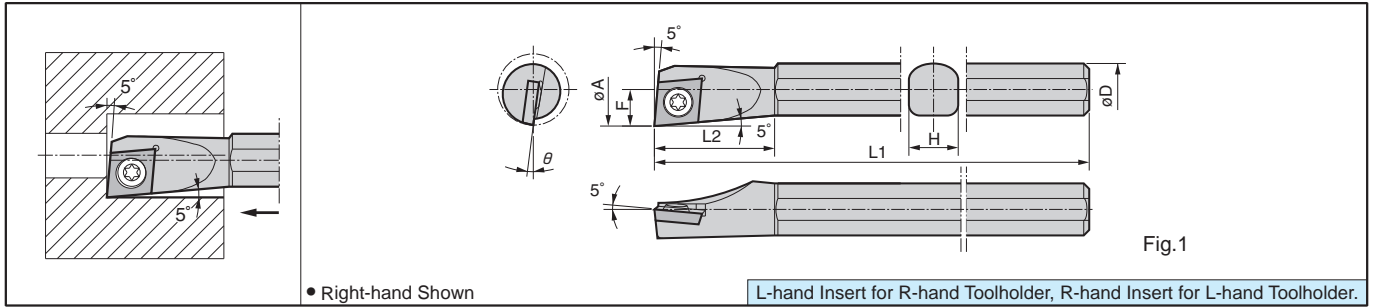

S...SCLP Steel Bar (Boring / Internal Facing)

Max. Overhang Length L/D≈-3

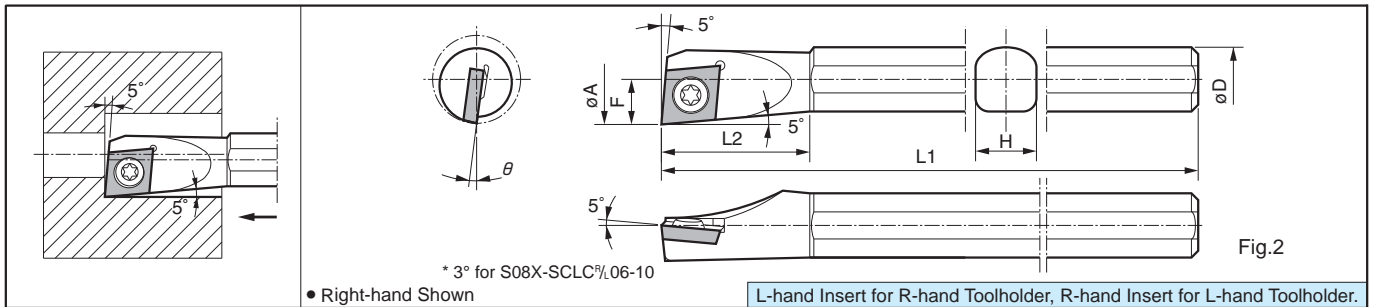

C...SCLP Carbide Shank Bar (Boring / Internal Facing)

Max. Overhang Length L/D≈-7

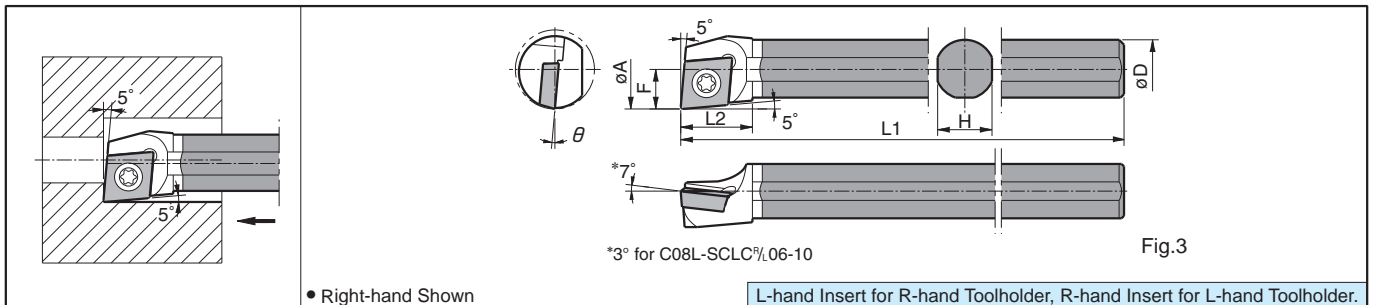

A...SCLP-E Excellent Twin-Hole Bar (Boring / Internal Facing: with Coolant Hole)

Max. Overhang Length L/D≈-5

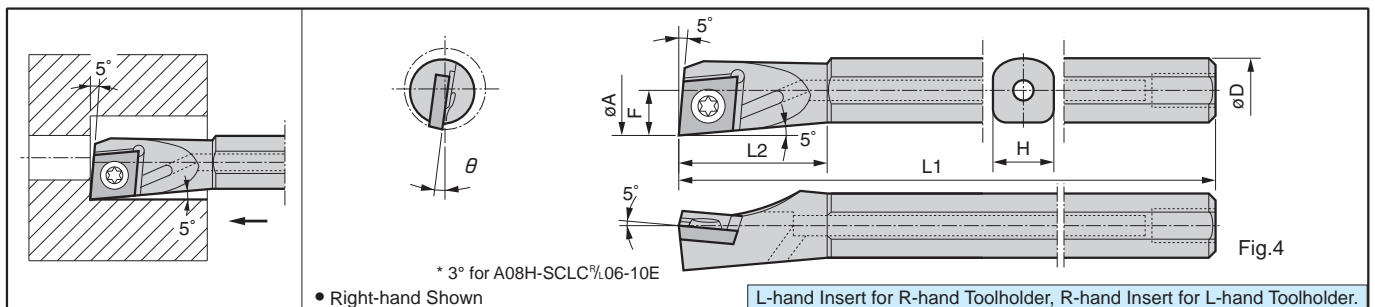

E...SCLP Carbide Twin-Hole Bar (Boring / Internal Facing: with Coolant Hole)

Max. Overhang Length L/D≈-7

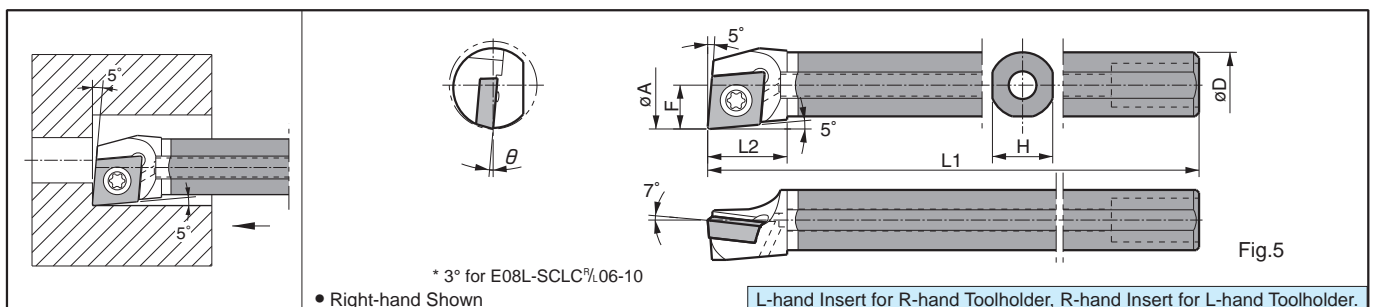

F



Boring