







(mm)

(mm)

55°Diamond • Negative with Hole

Description	A	T	ød
DN_1104_	9.525	4.76	3.81
DN_1504_	12.70	4.76	5.16

Insert	Description	Dim. (mm)	CVD Coated Carbide											PVD Coated Carbide	Cermet	Carbide	Ref. Page for Toolholder	Applicable Chipbreaker Range																	
			TN6010	TN6020	TN60	PV7005	PV7010	PV7020	CA5505	CA5515	CA5525	CA5535	CA6515						CA6525	CA4010	CA4115	CA4120	CA4505	CA4515	PR930	PR1005	PR1025	PR1125	KW10						
Roughing	 DNMG 150408PH 150412PH 150416PH DNMG 150608PH 150612PH 150616PH	0.8						●	●																										
		1.2						●	●																										
		1.6						●	●																										
Single Sided / Roughing	 High Feed DNMM 150408PX 150412PX 150416PX DNMM 150608PX 150612PX 150616PX	0.8						●	●																										
		1.2						●	●																										
		1.6						●	●																										
Low Carbon Steel	 Finishing DNMG 150404XP 150408XP DNMG 150604XP 150608XP	0.4	●	●		●	●	●	●																										
		0.8	●	●		●	●	●	●																										
	 Finishing Tough Edge DNMG 150404XP-T 150408XP-T	0.4		●																															
		0.8		●																															
	 Medium DNMG 150404XQ 150408XQ DNMG 150604XQ 150608XQ	0.4	●	●		●	●	●	●																										
		0.8	●	●		●	●	●	●																										
	 Roughing DNMG 150408XS DNMG 150608XS	0.8	●	●			●	●	●	●																									
		0.8	●	●			●	●	●	●																									

Classification of usage

- : Free-cutting steel
- : Carbon Steel and Alloy Steel
- ⊛: Stainless Steel
- ⊙: Gray Cast Iron
- ⊚: Nodular Cast Iron
- ⊜: Non-ferrous Metals
- ⊝: Heat-resistant alloy
- ⊞: Titanium Alloy
- ⊠: Hard Materials

Classification of usage

- ⊛: Interruption / 1st Choice
- ⊜: Interruption / 2nd Choice
- ⊝: Light Interruption / 1st Choice
- ⊞: Light Interruption / 2nd Choice
- ⊠: Continuous / 1st Choice
- ⊡: Continuous / 2nd Choice

(In case hardness is under 45HRC)

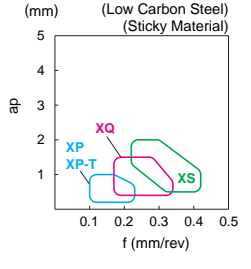
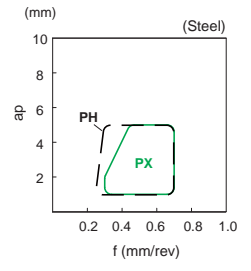

B

Negative

C

D

R

S

T

V

W

Insert (Turning)

For grades { TN30 PV60 PR905 } , See Page B41

● : Std. Item ○ : Check Availability R : Std. Item (R-hand Only) L : Std. Item (L-hand Only) www.kyocera-tools.ru

Inserts are sold in 10 piece boxes.