

SVLP (External / Copying)

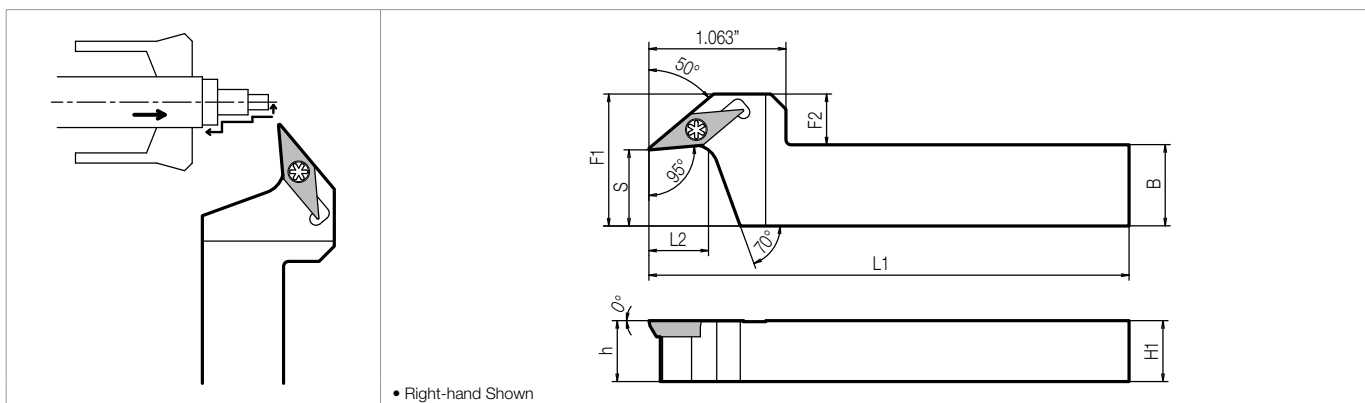

Toolholder Dimensions

Part Number	Stock	Unit	Dimensions							Standard Corner-R(r)	Spare Parts	
			H1=h	B	L1	L2	F1	F2	S		Clamp Screw	Wrench
SVLPR 52-2JX-F9	●	inch	0.500	0.625	4.750	0.472	1.000	0.375	0.562	0.008	SB-2570TR	FT-15
62.5-2JX-F9	●		0.625	0.750	4.750	0.472	1.000	0.250	0.562			
SVLPR 1216JX-11-F15	○	mm	12	16	120	12	26	10	15	0.2	SB-2570TR	FT-8
1620JX-11-F15	○		16	20	120	12	26	6	15			

Applicable Inserts

Application	Minute D.O.C.	Finishing	Finishing	Finishing / Precision	Low Feed	Low Feed / Precision
Ref. Page	➔ B80	➔ B80	➔ B80	➔ B81	➔ B81	➔ B81
Insert	CF	CK	GF	R-FSF	FR-U	FR-USF
Toolholder						
SVLPR..-2JX-F.. SVLPR..-11-F..	VPGT22..	VPGT22..	VPGT22..	VPET22..	VPET22..	VPET22..

Recommended Cutting Conditions ➔ E46

One Toolholder for Complex Workpieces

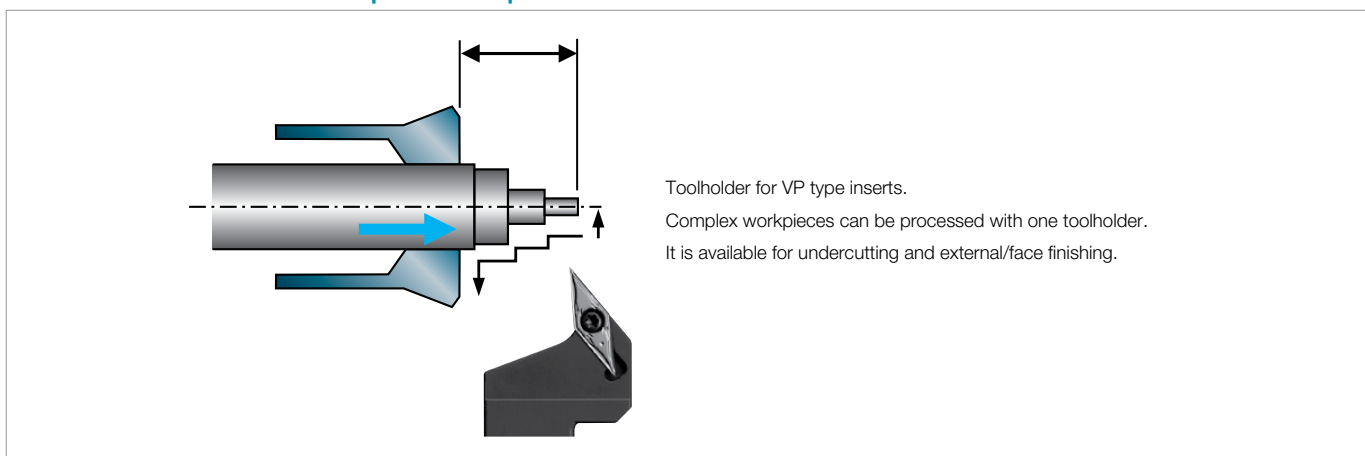

GRADES	A
INSERTS	B
CBN & POD	C
TOOLHOLDERS	D
SMALL TOOLS	E
BORING	F
GROOVING	G
CUT-OFF	H
THREADING	J
HSK TOOLING	N
SPARE PARTS	P
TECHNICAL	R
INDEX	T