

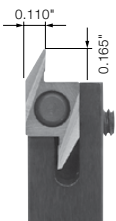

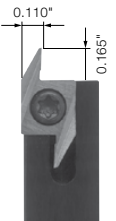

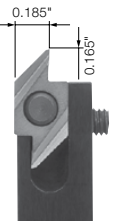

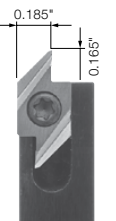
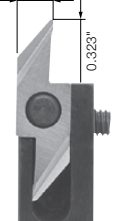
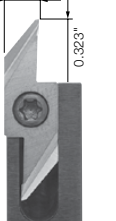

TURNING SUMMARY

Back Turning

						
AABS-40F	SABS-40F	AABW-40F	SABW-40F	AABW-50F	SABW-50F	KTKF
Back Clamp Edge Width: 0.110" / 2.8mm D.O.C. ~-0.158" / ~4.0mm	Screw Clamp Edge Width: 0.110" / 2.8mm D.O.C. ~-0.158" / ~4.0mm	Back Clamp Edge Width: 0.185" / 4.7mm D.O.C. ~-0.158" / ~4.0mm	Screw Clamp Edge Width: 0.185" / 4.7mm D.O.C. ~-0.158" / ~4.0mm	Back Clamp Edge Width: 0.185" / 4.7mm D.O.C. ~-0.197" / ~5.0mm	Screw Clamp Edge Width: 0.185" / 4.7mm D.O.C. ~-0.197" / ~5.0mm	Screw Clamp Edge Width: 0.059"-0.150" / 1.5mm-3.8mm D.O.C. 0.071"-0.217" / 1.8mm-5.5mm
 E17	 E17	 E18	 E18	 E19	 E19	 E12

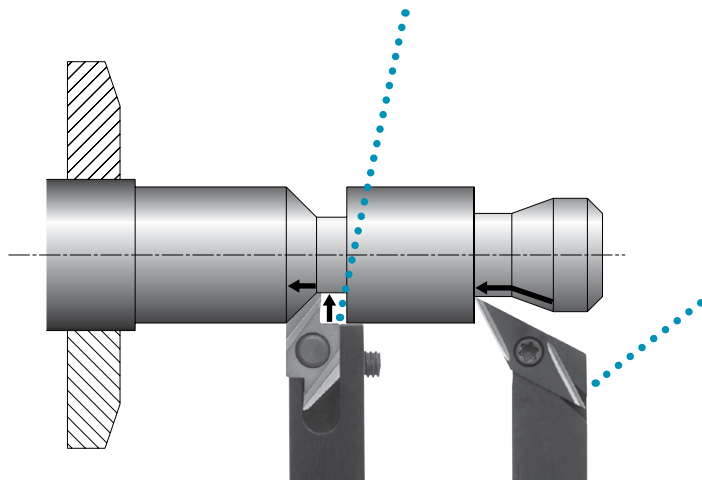

External / Facing / Copying / Undercutting

	
SVPB	SVPP-FF
Screw Clamp	Screw Clamp (Without Offset)
 E31	 E33

Tooling Example ② - CNC Automatic Lathe (Gang Type)

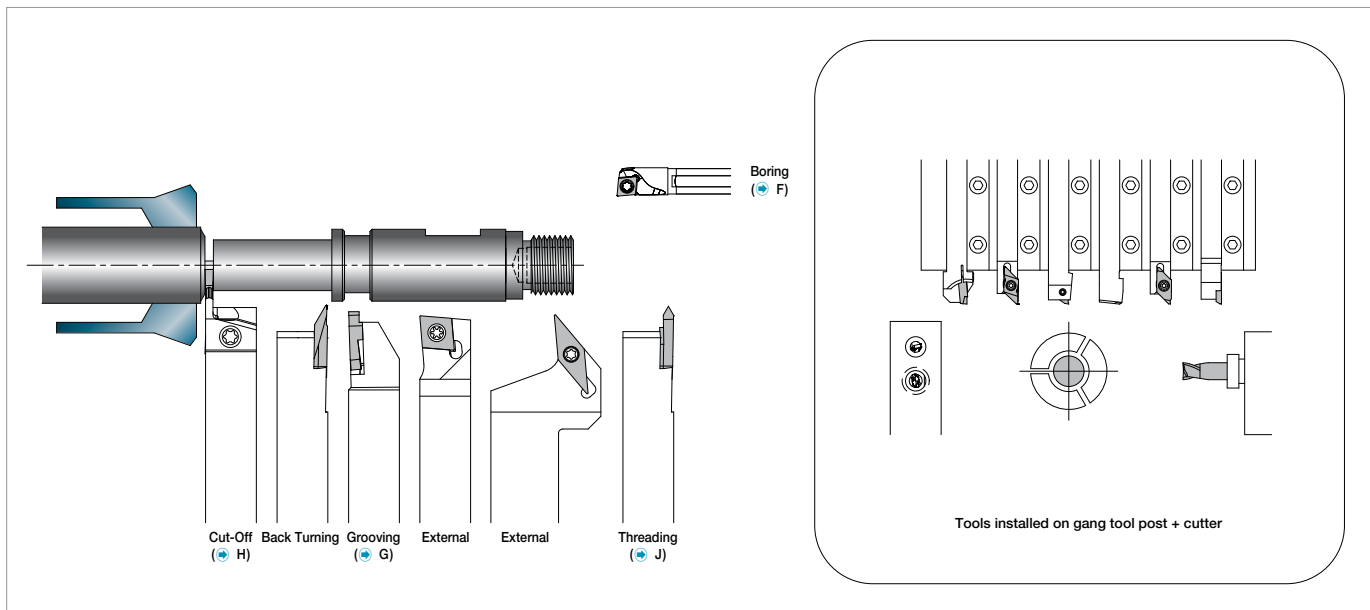

GRADES	A
INSERTS	B
CBN & PCD	C
TOOLHOLDERS	D
SMALL TOOLS	E
BORING	F
GROOVING	G
CUT-OFF	H
THREADING	J
HSK TOOLING	N
SPARE PARTS	P
TECHNICAL	R
INDEX	T