







TURNING SUMMARY

External / Copying

						
ADJC-FF	SDJC-FF	SDJC	SDLC-FF SDLP-FF	SDLN	SDNC-F	SDNC
Back Clamp Without Offset	Screw Clamp Without Offset	Screw Clamp	Screw Clamp Without Offset	Screw Clamp Without Offset	Screw Clamp	Screw Clamp
➔ E24	➔ E25	➔ E25	➔ E26, ➔ E28	➔ E38	➔ E27	➔ E27

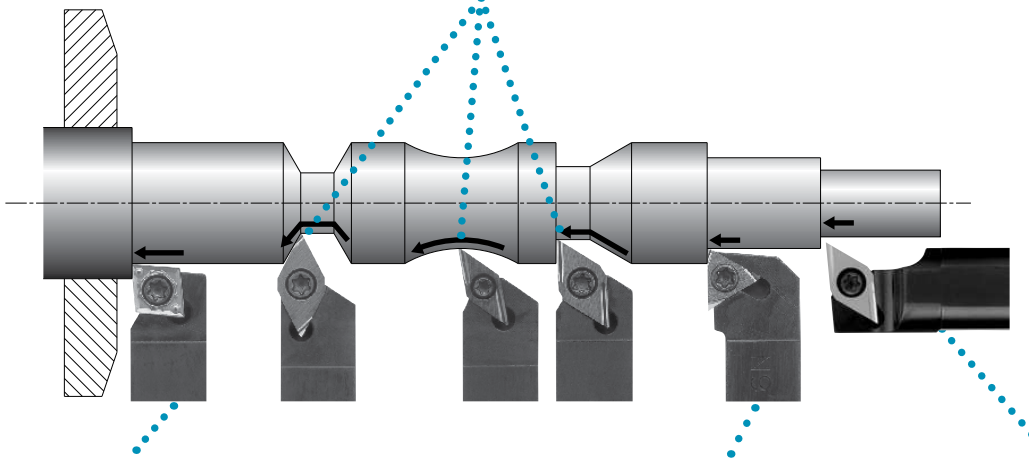

External / Facing

			
ACLFC-FF	SCLC-FF	SCLC	SCLN-FF
Back Clamp Without Offset	Screw Clamp Without Offset	Screw Clamp	Screw Clamp Without Offset
➔ E22	➔ E23	➔ E23	➔ E38

External

	
STGC(P)	STLN-FF
Screw Clamp	Screw Clamp Without Offset
➔ E29	➔ E39

External Sleeve Holder

S...SDLC
Screw Clamp Shank Dia. Ø0.625"~Ø1.000" Ø12.0mm~Ø25.4mm
➔ E35

Tooling Example ① - CNC Automatic Lathe (Gang Type)

