

PTGN (External)

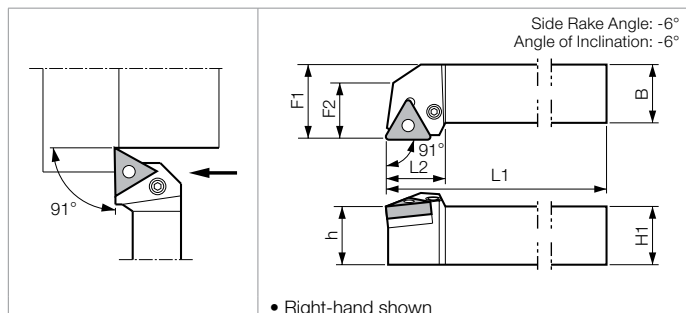

PTFN (Facing)

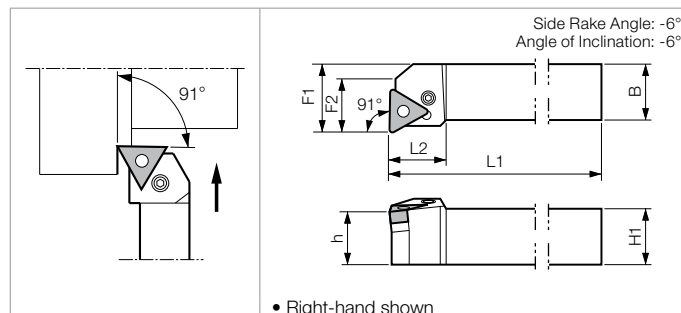

Toolholder Dimensions

Part Number	Stock		Unit	Dimensions						Standard Corner-R(°)	Spare Parts					
	R	L		H1=h	B	L1	L2	F1	F2		Lever	Lock Screw	Shim	Shim Pin	Punch	Wrench
PTGN% 12-3B	●		Inch	0.75	0.75	4.50	0.96	1.00	0.80	1/32	LL-1N	LS-1N	LT-32N *LT-32N-20	LSP-1	PC-1	LW-2.5
PTGN% 1212F-11	○	○	mm	12	12	80	18.0	16	12.0	0.8	LL-03N	LS-03N	-	P-03	-	FH-2
1616H-11	○	○		16	16	100	22.0	20	14.0	0.8	LL-03TN	LS-03SN	-	P-03S	-	FH-2.5
2020K-11	○	○		20	20	125	22.0	25	20.0	0.8	LL-03TN	LS-03SN	-	P-03S	-	FH-2.5
2525M-11	○	○		25	25	150	22.0	32	22.0	0.8	LL-03TN	LS-03SN	-	P-03S	-	FH-2.5
PTGN% 1616H-16	○	○	mm	16	16	100	24.0	20	17.0	0.8	LL-1N	LS-1N	LT-32N *LT-32N-20	LSP-1	PC-1	FH-2.5
2020H-16*	○			20	20	100	24.0	25	20.0	0.8	LL-1N	LS-1N	LT-32N *LT-32N-20	LSP-1	PC-1	FH-2.5
2020K-16	○	○		20	20	125	24.0	25	20.0	0.8	LL-1N	LS-1N	LT-32N *LT-32N-20	LSP-1	PC-1	FH-2.5
2525M-16	●	○		25	25	150	24.0	32	20.0	0.8	LL-1N	LS-1N	LT-32N *LT-32N-20	LSP-1	PC-1	FH-2.5
PTGN% 2525M-22	○	○		25	25	150	29.0	32	24.0	0.8	LL-2N	LS-2N	LT-42N *LT-42N-20	LSP-2	PC-2	LW-3
PTFN% 12-3C	●	●	Inch	0.75	0.75	5.00	0.88	1.00	0.83	1/32	LL-1N	LS-1N	LT-32N *LT-42N-20	LSP-1	PC-1	FH-2.5
16-3D	●	●		1.00	1.00	6.00	0.88	1.25	0.88	1/32	LL-1N	LS-1N	LT-32N *LT-42N-20	LSP-1	PC-1	FH-2.5
16-4D	●			1.00	1.00	6.00	1.10	1.25	0.97	1/32	LL-2N	LS-2N	LT-42N *LT-42N-20	LSP-2	PC-2	LW-3
PTFN% 1212F-11	○	○	mm	12	12	80	15.0	16	12.5	0.8	LL-03N	LS-03N	-	P-03	-	FH-2
PTFN% 1616H-11	○	○		16	16	100	22.5	20	15.0	0.8	LL-03TN	LS-03SN	-	P-03S	-	FH-2.5
2020K-11	○	○		20	20	125	22.5	25	19.0	0.8	LL-03TN	LS-03SN	-	P-03S	-	FH-2.5
2525M-11	○	○		25	25	150	22.5	32	25.0	0.8	LL-03TN	LS-03SN	-	P-03S	-	FH-2.5
PTFN% 2020K-16	○	○	mm	20	20	125	22.0	25	21.0	0.8	LL-1N	LS-1N	LT-32N *LT-32N-20	LSP-1	PC-1	FH-2.5
2525M-16	○	○		25	25	150	23.0	32	22.0	0.8	LL-1N	LS-1N	LT-32N *LT-32N-20	LSP-1	PC-1	FH-2.5
PTFN% 2525M-22	○	○		25	25	150	28.0	32	25.0	0.8	LL-2N	LS-2N	LT-42N *LT-42N-20	LSP-2	PC-2	LW-3

* Mark indicates short shank type.

• When using inserts whose corner-R(r_e) is greater than 1/16", please purchase a shim with * mark and use it in order to prevent workpiece and shim from interfering each other.

Applicable Inserts

Toolholder	Insert	33..
PTGN% ...12-3B	TN□A TN□G TN□M	33..
PTFN% ...12-3C	TN□A	33..
PTFN% ...16-3D	TN□G	43..
PT□N% 12...-11	TN□□	22..
PT□N% ...-11	TN□□	23..
PT□N% ...-16	TN□A TN□G	33..
PT□N% ...-22	TN□M	43..

PTGN% 1212F-11 } Insert applicable for above
PTFN% 1212F-11 }
TN□□1103-type Insert is applicable.

• PTFN% : Left-hand Insert for Right-hand Toolholder, Right-hand Insert for Left-hand Toolholder