

Magic Drill DRZ

Inch-Inch (2xD)

DRZ (Drilling Depth : 2 x D) Inch Dimension

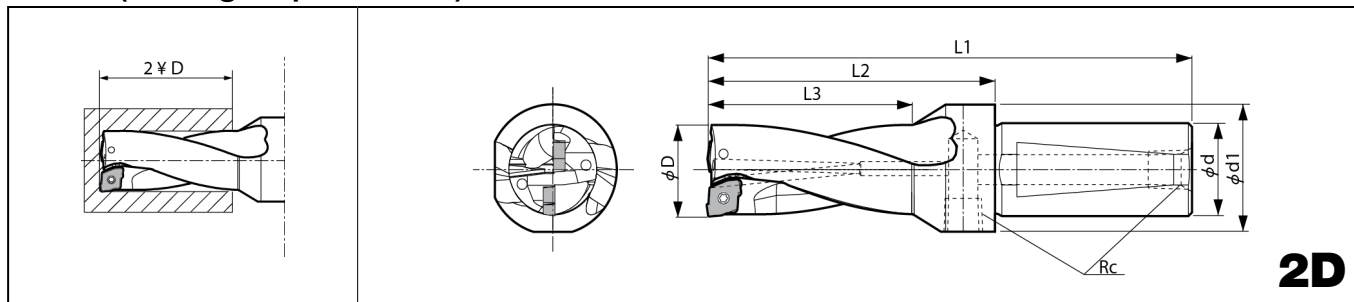

2D

● Toolholder Dimensions

Description	Stock	No. of Insert	Dimension (inch)						Max. Offset (Radial)	Spare Parts			Applicable Inserts ● Page 6					
			ØD	L1	L2	L3	Ød	Ød1		Rc	Insert Screw	Wrench		Plug				
S75 -DRZ5621125-05G	●	2	0.562	3.87	2.18	1.125	0.75	1.06	1/8 NPT	+ 0.020	SB-2045TR	FT-6	GP-1N	ZCMT050203 ZCMT050203SP ZCMT050203SU				
S100 -DRZ6251250-06G	●	2	0.625	4.52	2.39	1.250	1.00	1.26	1/8 NPT	+ 0.043	SB-2260TR	DT-7	GP-1N	ZCMT06T204 ZCMT06T204SP ZCMT06T204SU				
-DRZ6561312-06G	●		0.656	4.52	2.39	1.312				+ 0.034								
-DRZ6881375-06G	●		0.688	4.56	2.43	1.375				+ 0.027								
-DRZ7501500-06G	●		0.750	4.73	2.61	1.500				+ 0.020								
-DRZ8121625-06G	●		0.812	4.93	2.81	1.625				+ 0.014								
-DRZ8751750-08G	●		0.875	5.02	2.90	1.750				+ 0.055								
-DRZ9381875-08G	●		0.938	5.17	3.05	1.875				+ 0.043								
-DRZ10002000-08G	●		1.000	5.24	3.11	2.000				+ 0.028								
-DRZ10622125-10G	●		1.062	5.67	3.54	2.125				+ 0.098								
-DRZ11252250-10G	●		1.125	5.74	3.62	2.250				+ 0.073								
-DRZ11882375-10G	●	1.188	5.86	3.74	2.375	+ 0.067	SB-4085TR	DT-15	GP-2N	ZCMT10T304 ZCMT10T304SP								
-DRZ12502500-10G	●	1.250	5.92	3.79	2.500	+ 0.047												
S125 -DRZ13122625-12G	●	2	1.312	6.82	4.10	2.625	1.25	2.17	1/4 NPT	+ 0.110	SB-5085TR	DT-20	GP-2N	ZCMT12T306 ZCMT12T304SP				
-DRZ13752750-12G	●		1.375	6.98	4.27	2.750				+ 0.094								
-DRZ14382875-12G	●		1.438	7.07	4.35	2.875				+ 0.078								
-DRZ15003000-12G	●		1.500	7.19	4.47	3.000				+ 0.067								
-DRZ15623125-12G	●		1.562	7.29	4.57	3.125				+ 0.047								
-DRZ16253250-15G	●		1.625	7.34	4.62	3.250				+ 0.150								
-DRZ16883375-15G	●		1.688	7.49	4.78	3.375				+ 0.138								
-DRZ17503500-15G	●		1.750	7.57	4.85	3.500				+ 0.122								
-DRZ18123625-15G	●		1.812	7.78	5.06	3.625				+ 0.106					SB-5085TR	DT-20	GP-2N	ZCMT150408 ZCMT150406SP
-DRZ18753750-15G	●		1.875	7.97	5.26	3.750				+ 0.087								
-DRZ19383875-15G	●	1.938	8.05	5.34	3.875	+ 0.070												
-DRZ20004000-15G	●	2.000	8.05	5.34	4.000	+ 0.055												

- When offset machining, reduce feed rate to .003ipr or less
- See ● Page 77 for Adjustable Sleeve ASL.

- : Stock Standard
- : World Express

Recommended Cutting Conditions ● Page 19

Magic Drill DRZ
Drilling