



# Magic Drill DRS



Magic Drill DRS

Drilling

- 10mm diameter drilling with an indexable insert
- Inner & outer edges on one insert makes replacement easy
- Small chips with good chip evacuation
- High-speed stable machining for high efficiency
- Productivity improvement and significant cost reduction
- Possible to drill into a slant face without pre-drilling

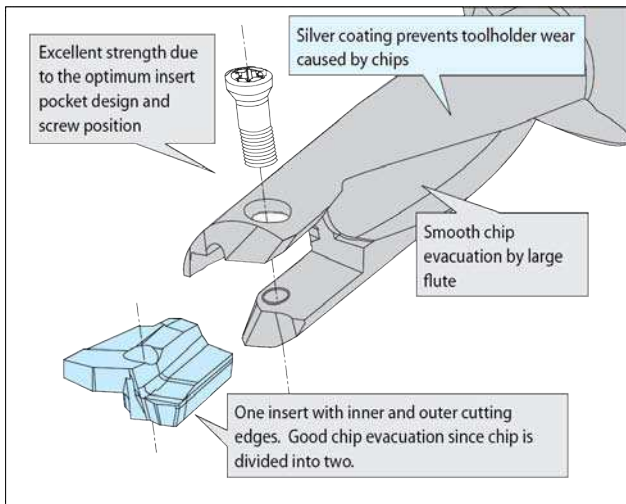

## ■ Magic Drill DRS Insert

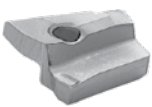
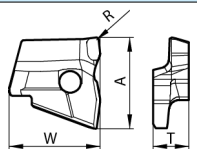
Shape	Description	Dimensions (inch)					Insert Grade Coated Carbide		
		A	T	Ød	W	R	PR1230	PR1210	PR660
 	DS 100	0.346	0.138	-	0.354	0.008	●	●	●
	105	0.366	0.146	-	0.382	0.008	●	●	●
	110	0.386	0.154	-	0.394	0.008	●	●	●
	115	0.402	0.161	-	0.406	0.008	●	●	●
	120	0.425	0.169	-	0.429	0.010	●	●	●

Insert Grade Features ● Page 1

● : Stock Standard  
○ : World Express