

Magic Drill DRC

Flanged Shank (3xD)

Toolholder Identification System

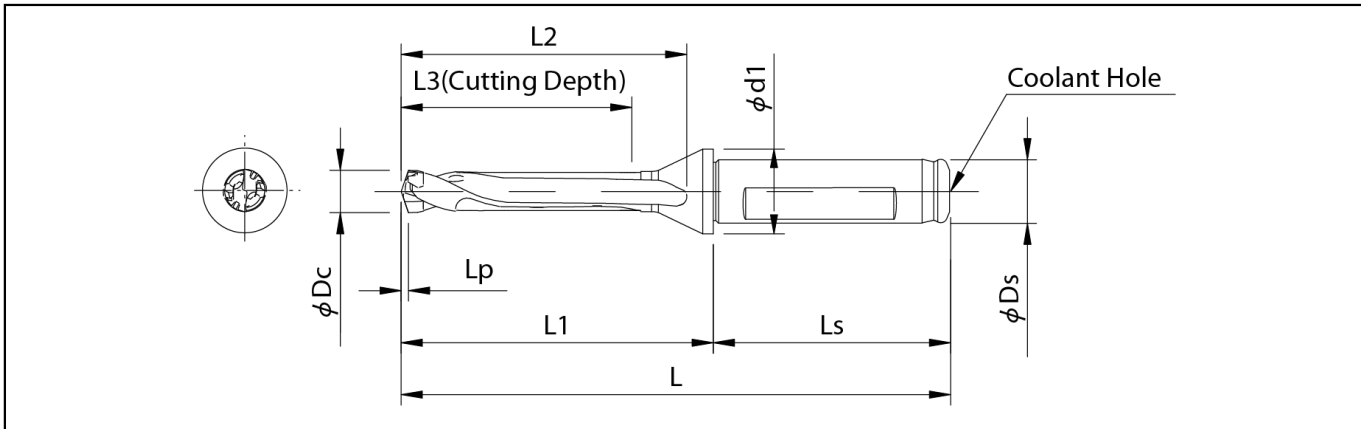
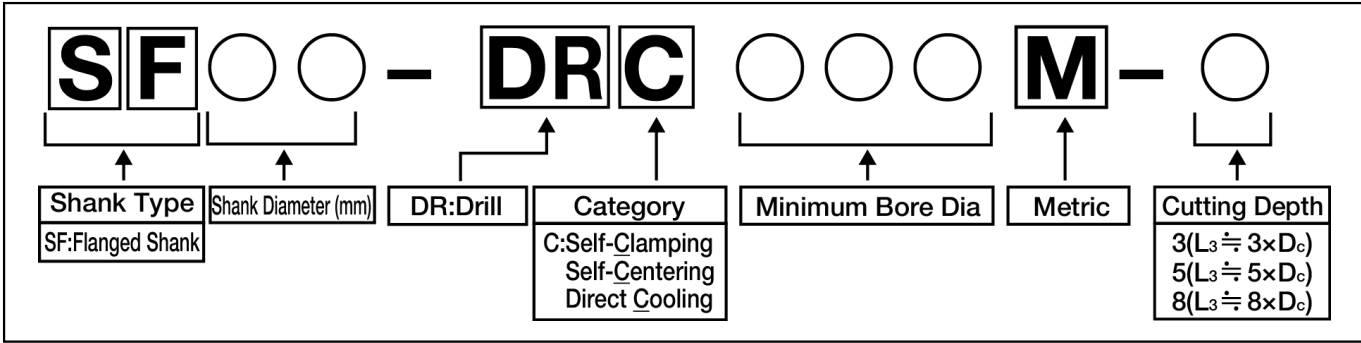

• Lp indicates distance from drill point to corner edge [See 38-40](#)

SF-DRC (Cutting Depth : 3xD)

Toolholder Dimensions

Description (ISO)	Stock	ØDc Applicable Insert Dia.(inch)		Dimensions(mm)						Spare Parts	Applicable Insert (ANSI) Page 38-40	
		min.	max.	ØDs (h6)	L	L1	L2	L3	Ls			Ød1
SF12-DRC080M-3	○	7.94	8.49	12	86	41	35	26	45	16	WDR8 (WDR17)	DC03125-SC~DC03307-SC
SF12-DRC085M-3	○	8.50	8.99		88	43	37	27				DC03346-SC~DC03504-SC
SF12-DRC090M-3	○	9.00	9.49		90	45	39	29				DC03543-SC~DC03701-SC
SF12-DRC095M-3	○	9.50	9.99		92	47	41	30				DC03740-SC~DC03898-SC
SF16-DRC100M-3	○	10.00	10.49	16	97	49	43	32	48	20	WDR10 (WDR17)	DC03937-SC~DC04094-SC
SF16-DRC105M-3	○	10.50	10.99		99	51	45	33				DC04134-SC~DC04291-SC
SF16-DRC110M-3	○	11.00	11.49		101	53	47	35				DC04331-SC~DC04488-SC
SF16-DRC115M-3	○	11.50	11.99		103	55	49	36				DC04528-SC~DC04685-SC
SF16-DRC120M-3	○	12.00	12.49		106	58	52	38			DC04724-SC~DC04882-SC	
SF16-DRC125M-3	○	12.50	12.99		108	60	54	39			DC04921-SC~DC05080-SC	
SF16-DRC130M-3	○	13.00	13.49		110	62	56	41			DC05118-SC~DC05276-SC	
SF16-DRC135M-3	○	13.50	13.99		112	64	58	42			DC05315-SC~DC05471-SC	
SF16-DRC140M-3	○	14.00	14.49	20	114	66	60	44	50	25	WDR14 (WDR17)	DC05512-SC~DC05669-SC
SF16-DRC145M-3	○	14.50	14.99		116	68	62	45				DC05709-SC~DC05866-SC
SF20-DRC150M-3	○	15.00	15.99		122	72	66	48				DC05906-SC~DC06220-SC
SF20-DRC160M-3	○	16.00	16.99		126	76	70	51				DC06300-SC~DC06654-SC
SF20-DRC170M-3	○	17.00	17.99	25	131	81	75	54	56	32	WDR17	DC06692-SC~DC07047-SC
SF25-DRC180M-3	○	18.00	18.99		141	85	79	57				DC07087-SC~DC07441-SC
SF25-DRC190M-3	○	19.00	19.99		145	89	83	60				DC07480-SC~DC07835-SC
SF25-DRC200M-3	○	20.00	20.99		149	93	87	63				DC07874-SC~DC08264-SC

Recommended Cutting Conditions [Page 47](#)

● : Stock Standard
○ : World Express