

■ DRX (Drilling Depth : 4 x D) Metric Diameter

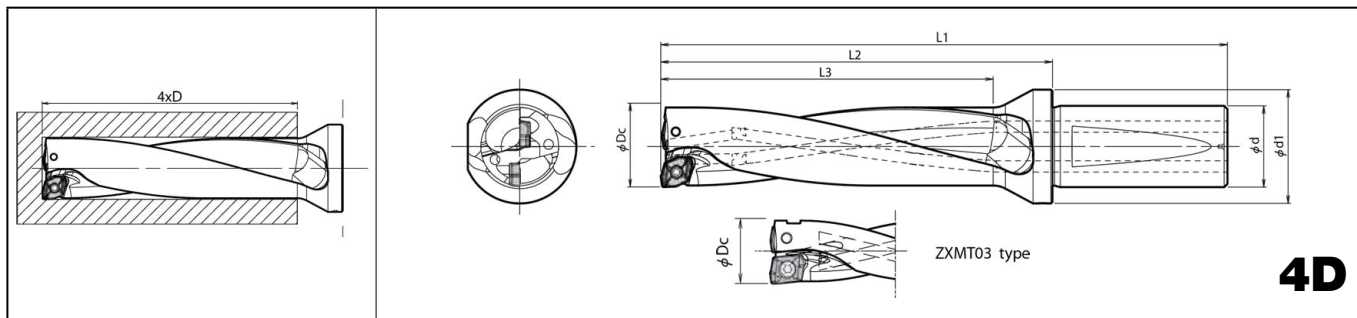

● Toolholder Dimensions

| Description | Stock | No. of insert | Dimension (mm) | | | | | Max. Offset (Radial) (mm) | Spare Parts | | Applicable Insert ● Page 25 | | |
|-------------------|-------|---------------|----------------|-----|-----|------|------|---------------------------|-------------|--------------|--------------------------------|--|------|
| | | | ØDc | L1 | L2 | L3 | Ød | | Ød1 | Insert Screw | | Wrench | |
| S20 -DRX120M-4-03 | ○ | 2 | 12 | 112 | 69 | 48 | 20 | 27 | +0.5 | SB-2042TRG | DTM-6 | ZXMT030203○○-E (External) ZXMT030203GM-I (Internal) | |
| -DRX125M-4-03 | ○ | | 12.5 | 114 | 71 | 50 | | | | | | | +0.4 |
| -DRX130M-4-03 | ○ | | 13 | 116 | 73 | 52 | | | | | | | +0.3 |
| S20 -DRX135M-4-04 | ○ | 2 | 13.5 | 118 | 75 | 54 | 20 | 27 | +0.5 | SB-2042TRG | DTM-6 | ZXMT040203○○ | |
| -DRX140M-4-04 | ○ | | 14 | 120 | 77 | 56 | | | | | | | +0.4 |
| -DRX145M-4-04 | ○ | | 14.5 | 122 | 79 | 58 | | | | | | | +0.3 |
| -DRX150M-4-04 | ○ | | 15 | 124 | 81 | 60 | | | | | | | +0.2 |
| S25 -DRX155M-4-05 | ○ | 2 | 15.5 | 140 | 86 | 62 | 25 | 32 | +0.8 | SB-2045TR | DTM-6 | ZXMT05T203○○ | |
| -DRX160M-4-05 | ○ | | 16 | 142 | 87 | 64 | | | | | | | +0.7 |
| -DRX165M-4-05 | ○ | | 16.5 | 144 | 90 | 66 | | | | | | | +0.5 |
| -DRX170M-4-05 | ○ | | 17 | 146 | 91 | 68 | | | | | | | +0.4 |
| -DRX175M-4-05 | ○ | | 17.5 | 148 | 94 | 70 | | | | | | | +0.3 |
| -DRX180M-4-05 | ○ | | 18 | 150 | 95 | 72 | | | | | | | +0.2 |
| -DRX185M-4-06 | ○ | 2 | 18.5 | 149 | 95 | 74 | 25 | 32 | +0.9 | SB-2250TR | DTM-7 | ZXMT06T204○○ | |
| -DRX190M-4-06 | ○ | | 19 | 151 | 97 | 76 | | | | | | | +0.8 |
| -DRX195M-4-06 | ○ | | 19.5 | 153 | 99 | 78 | | | | | | | +0.7 |
| -DRX200M-4-06 | ○ | | 20 | 155 | 101 | 80 | | | | | | | +0.5 |
| -DRX205M-4-06 | ○ | | 20.5 | 157 | 103 | 82 | | | | | | | +0.4 |
| -DRX210M-4-06 | ○ | | 21 | 159 | 105 | 84 | | | | | | | +0.3 |
| -DRX215M-4-06 | ○ | | 21.5 | 161 | 107 | 86 | | | | | | | +0.2 |
| -DRX220M-4-07 | ○ | | 22 | 163 | 108 | 88 | | | | | | | +1.2 |
| -DRX225M-4-07 | ○ | | 22.5 | 165 | 111 | 90 | | | | | | | +1.0 |
| -DRX230M-4-07 | ○ | | 23 | 167 | 112 | 92 | | | | | | | +0.9 |
| -DRX235M-4-07 | ○ | 23.5 | 169 | 115 | 94 | +0.8 | | | | | | | |
| -DRX240M-4-07 | ○ | 2 | 24 | 171 | 116 | 96 | 25 | 35 | +0.7 | SB-2570TR | DTM-8 | ZXMT070305○○ | |
| -DRX245M-4-07 | ○ | | 24.5 | 173 | 119 | 98 | | | | | | | +0.5 |
| -DRX250M-4-07 | ○ | | 25 | 175 | 120 | 100 | | | | | | | +0.4 |
| -DRX255M-4-07 | ○ | | 25.5 | 177 | 123 | 102 | | | | | | | +0.3 |
| -DRX260M-4-07 | ○ | | 26 | 179 | 124 | 104 | | | | | | | +0.2 |
| S32 -DRX270M-4-09 | ○ | | 2 | 27 | 190 | 130 | | | | | | | 108 |
| -DRX280M-4-09 | ○ | 28 | | 194 | 134 | 112 | +1.3 | | | | | | |
| -DRX290M-4-09 | ○ | 29 | | 198 | 138 | 116 | +1.1 | | | | | | |
| -DRX300M-4-09 | ○ | 30 | | 202 | 142 | 120 | +0.8 | | | | | | |
| -DRX310M-4-09 | ○ | 31 | | 206 | 146 | 124 | +0.6 | | | | | | |
| S40 -DRX320M-4-11 | ○ | 2 | 32 | 223 | 154 | 128 | 40 | 50 | +2.2 | SB-4085TR | DTM-15 | ZXMT11T306○○ | |
| -DRX330M-4-11 | ○ | | 33 | 227 | 158 | 132 | | | | | | | +1.9 |
| -DRX340M-4-11 | ○ | | 34 | 231 | 162 | 136 | | | | | | | +1.7 |
| -DRX350M-4-11 | ○ | | 35 | 235 | 166 | 140 | | | | | | | +1.4 |
| -DRX360M-4-11 | ○ | | 36 | 239 | 170 | 144 | | | | | | | +1.2 |
| -DRX370M-4-11 | ○ | | 37 | 243 | 174 | 148 | | | | | | | +0.9 |
| -DRX380M-4-11 | ○ | | 38 | 247 | 178 | 152 | | | | | | | +0.7 |

● When offset machining, reduce feed rate to .002ipr or less
 ● See ● Page 77 for Adjustable Sleeve SHE.

● : Stock Standard
 ○ : World Express