

Magic Drill DRZ

Inch-Inch (4xD)

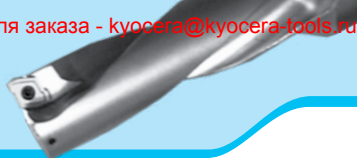

DRZ (Drilling Depth : 4 x D) Inch Dimension

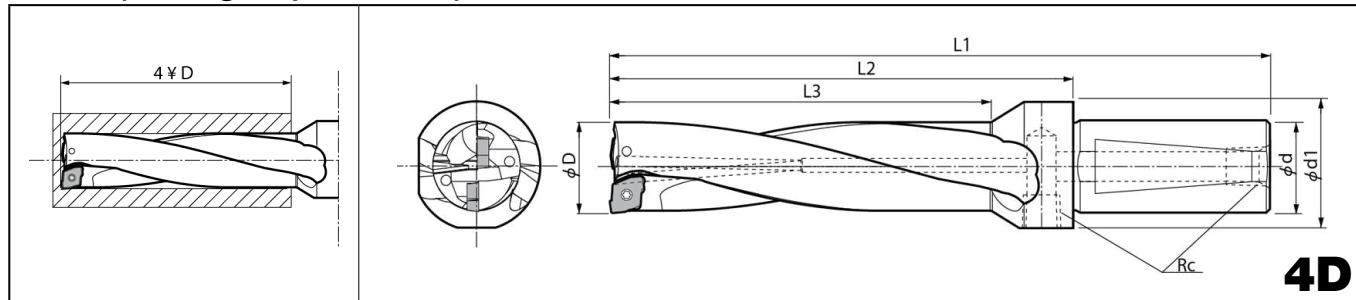

Toolholder Dimensions

Description	Stock	No. of Insert	Dimension (inch)							Max. Offset (Radial)	Spare Parts			Applicable Inserts ● Page 6		
			ØD	L1	L2	L3	Ød	Ød1	Rc		Insert Screw	Wrench	Plug			
S075 -DRZ5622250-05G	●	2	0.562	5.77	3.27	2.25	0.75	1.06	1/8 NPT	+ 0.020	SB-2045TR	FT-6	GP-1N	ZCMT050203 ZCMT050203SP ZCMT050203SU		
S100 -DRZ6252500-06G	●	2	0.625	6.65	3.65	2.50	1.26	1.26	1/8 NPT	+ 0.043	SB-2260TR	DT-7	GP-1N	ZCMT06T204 ZCMT06T204SP ZCMT06T204SU		
-DRZ6882750-06G	●		0.688	6.74	3.74	2.75									+ 0.027	
-DRZ7503000-06G	●		0.750	7.07	4.07	3.00									+ 0.020	
-DRZ8123250-06G	●		0.812	7.39	4.39	3.25									+ 0.014	
-DRZ8753500-08G	●	2	0.875	7.56	4.56	3.50	1.00	1.38	1/8 NPT	+ 0.055	SB-2570TR	DT-8	GP-1N	ZCMT080304 ZCMT080304SP		
-DRZ9383750-08G	●		0.938	7.77	4.77	3.75									+ 0.043	
-DRZ10004000-08G	●		1.000	8.06	5.06	4.00									+ 0.028	
-DRZ10624250-10G	●		1.062	8.55	5.55	4.25									+ 0.098	
-DRZ11254500-10G	●	2	1.125	8.84	5.84	4.50	1.65	1.65	1/4 NPT	+ 0.073	SB-4085TR	DT-15	GP-2N	ZCMT10T304 ZCMT10T304SP		
-DRZ11884750-10G	●		1.188	8.98	5.98	4.75									+ 0.067	
-DRZ12505000-10G	●		1.250	9.30	6.30	5.00									+ 0.047	
-DRZ13125250-12G	●		1.312	9.58	6.58	5.25									+ 0.110	
-DRZ13755500-12G	●	2	1.375	9.91	6.91	5.50	1.25	2.17	1/4 NPT	+ 0.094	SB-5085TR	DT-20	GP-2N	ZCMT12T306 ZCMT12T304SP		
-DRZ14385750-12G	●		1.438	10.07	7.07	5.75									+ 0.078	
-DRZ15006000-12G	●		1.500	10.35	7.35	6.00									+ 0.067	
-DRZ15626250-12G	●		1.562	10.50	7.50	6.25									+ 0.047	
S125 -DRZ16256500-15G	●	2	1.625	10.73	7.73	6.50	1.25	2.17	1/4 NPT	+ 0.150	SB-5085TR	DT-20	GP-2N	ZCMT150408 ZCMT150406SP		
-DRZ16886750-15G	●	1.688	11.37	7.87	6.75	2.17	+ 0.138									
-DRZ17507000-15G	●	1.750	11.70	8.20	7.00	2.17	+ 0.122									
-DRZ18127250-15G	●	1.812	12.06	8.56	7.25	2.36	+ 0.106									
-DRZ18757500-15G	●	2	1.875	12.28	8.78	7.50	1.50	2.36	1/4 NPT	+ 0.087	SB-5085TR	DT-20	GP-2N	ZCMT150408 ZCMT150406SP		
-DRZ19387750-15G	●		1.938	12.58	9.08	7.75									2.36	+ 0.070
-DRZ20008000-15G	●		2.000	12.63	9.13	8.00									2.36	+ 0.055

- When offset machining, reduce feed rate to .002ipr or less
- See ● Page 77 for Adjustable Sleeve ASL.

- : Stock Standard
- : World Express

Recommended Cutting Conditions ● Page 19

Magic Drill DRZ

Drilling