

■ DRZ (Drilling Depth : 3 x D) Inch Dimension

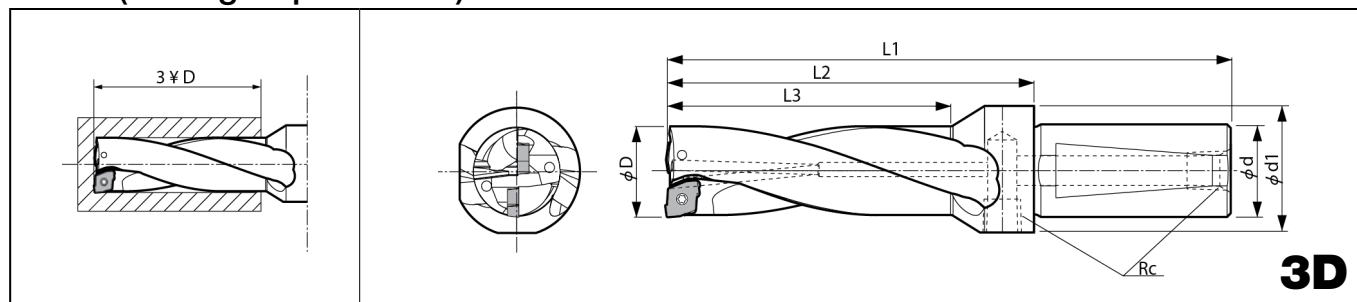

● Toolholder Dimensions

Description	Stock	No. of Insert	Dimension (inch)						Max. Offset (Radial)	Spare Parts			Applicable Inserts ● Page 6	
			ØD	L1	L2	L3	Ød	Ød1		Rc	Insert Screw 	Wrench 		Plug
S75 -DRZ5621687-05G	●	2	0.562	4.42	2.72	1.687	0.75	1.06	1/8 NPT	+ 0.020	SB-2045TR	FT-6	GP-1N	ZCMT050203 ZCMT050203SP ZCMT050203SU
S100 -DRZ6251875-06G	●	2	0.625	5.15	3.02	1.875	1.00	1.26	1/8 NPT	+ 0.043	SB-2260TR	DT-7	GP-1N	ZCMT06T204 ZCMT06T204SP ZCMT06T204SU
-DRZ6561969-06G	●		0.656	5.15	3.02	1.969				+ 0.034				
-DRZ6882062-06G	●		0.688	5.23	3.10	2.062				+ 0.027				
-DRZ7502250-06G	●		0.750	5.48	3.35	2.250				+ 0.020				
-DRZ8122438-06G	●		0.812	5.76	3.64	2.438				+ 0.014				
-DRZ8752625-08G	●		0.875	5.77	3.65	2.625				+ 0.055				
-DRZ9382814-08G	●		0.938	5.89	3.76	2.814				+ 0.043				
-DRZ10003000-08G	●		1.000	6.11	3.98	3.000				+ 0.028				
-DRZ10623187-10G	●		1.062	6.81	4.49	3.187				+ 0.098				
-DRZ11253375-10G	●		1.125	6.92	4.60	3.375				+ 0.073				
-DRZ11883562-10G	●	1.188	7.12	4.80	3.562	+ 0.067								
-DRZ12503750-10G	●	1.250	7.22	4.89	3.750	+ 0.047								
S125 -DRZ13123938-12G	●	2	1.312	8.00	5.28	3.938	1.25	2.17	1/4 NPT	+ 0.110	SB-5085TR	DT-20	GP-2N	ZCMT12T306 ZCMT12T304SP
-DRZ13754125-12G	●		1.375	8.24	5.53	4.125				+ 0.094				
-DRZ14384312-12G	●		1.438	8.37	5.65	4.312				+ 0.078				
-DRZ15004500-12G	●		1.500	8.57	5.85	4.500				+ 0.067				
-DRZ15624688-12G	●		1.562	8.69	5.97	4.688				+ 0.047				
-DRZ16254875-15G	●		1.625	8.83	6.11	4.875				+ 0.150				
-DRZ16885062-15G	●		1.688	8.93	6.21	5.062				+ 0.138				
-DRZ17505250-15G	●		1.750	9.18	6.47	5.250				+ 0.122				
-DRZ18125438-15G	●		1.812	9.47	6.75	5.438				+ 0.106				
-DRZ18755625-15G	●		1.875	9.65	6.93	5.625				+ 0.087				
-DRZ19385812-15G	●	1.938	9.86	7.15	5.812	+ 0.070								
-DRZ20006000-15G	●	2.000	9.88	7.17	6.000	+ 0.055								
							2.36		1/4 NPT		SB-5085TR	DT-20	GP-2N	ZCMT150408 ZCMT150406SP

● When offset machining, reduce feed rate to .003ipr or less

● : Stock Standard

● See ● Page 77 for Adjustable Sleeve ASL.

○ : World Express

Recommended Cutting Conditions ● Page 19



Magic Drill DRZ

Drilling