

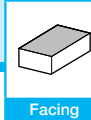

# MSRS15 HEAVY MILLING



Facing

## MSRS15 Face Mill (Metric Bore Dia.)

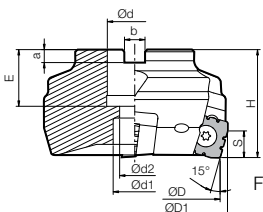
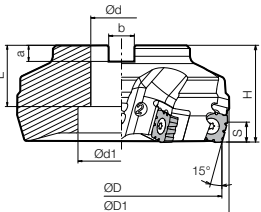
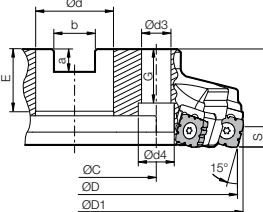
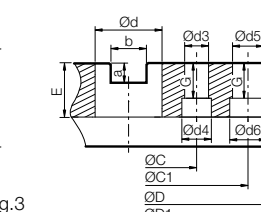

Rake Angle (°)		
Part Number	A.R.	R.R.
MSRS15080R...	+9°	-9°
MSRS15100R... MSRS15315R...	+9°	-5°

(Coarse Pitch Shown)

### Toolholder Dimensions (Bore Dia Ød: Metric)

Part Number	Stock	Unit	No. of Inserts	Dimensions																Drawing	Weight (kg)									
				ØD	ØD1	Ød	Ød1	Ød2	H	E	a	b	S	Ød3	Ød4	Ød5	Ød6	ØC	ØC1			ØG								
Coarse Pitch	MSRS 15080R-4T-M	○	4	80	87	27	20	13	50	24	7	12.4	12	14	20	-	-	66.7	-	28	Fig.1	1.3								
	15100R-4T-M	○	4	100	107	32	45	29		8	14.4	-									-	-	-	-	-	-	-	-	Fig.2	2.0
	15125R-6T-M	○	6	125	132	40	55	33		9	16.4	18									26	101.6	177.8	32	Fig.3	7.7				
	15160R-8T-M	○	8	160	167	60	-	60	38	15	25.7	22	32	Fig.4	17.0															
	15200R-10T-M	○	10	200	207	60	-		38	15	25.7	18	26	101.6	177.8	32	Fig.4	17.0												
	15250R-12T-M	○	12	250	257	60	-		38	15	25.7	18	26	101.6	177.8	32	Fig.4	17.0												
	15315R-14T-M	○	14	315	322	60	-		38	15	25.7	18	26	101.6	177.8	32	Fig.4	17.0												
Fine Pitch	MSRS 15080R-6T-M	○	6	80	87	27	20	13	50	24	7	12.4	12	14	20	-	-	66.7	-	28	Fig.1	1.3								
	15100R-6T-M	○	6	100	107	32	45	29		8	14.4	-									-	-	-	-	-	-	-	-	Fig.2	1.9
	15125R-8T-M	○	8	125	132	40	55	33		9	16.4	18									26	101.6	177.8	32	Fig.3	7.6				
	15160R-10T-M	○	10	160	167	60	-	60	38	15	25.7	22	32	Fig.4	17.0															
	15200R-12T-M	○	12	200	207	60	-		38	15	25.7	18	26	101.6	177.8	32	Fig.4	17.0												
	15250R-14T-M	○	14	250	257	60	-		38	15	25.7	18	26	101.6	177.8	32	Fig.4	17.0												
	15315R-16T-M	□	16	315	322	60	-		38	15	25.7	18	26	101.6	177.8	32	Fig.4	17.0												

- Mounting bolts (HH12X35) are included in MSRS15080R-○T-M.
- Cartridge is included in the coarse pitch cutters, but no Cartridge in the fine pitch.

### Spare Parts

Part Number	Spare Parts							
	Clamp Screw	Wrench	Cartridge	Clamp Screw	Wrench	Anti-seize Compound	Mounting Bolt	
Coarse Pitch	MSRS 15300R-4T	SB-60120TR	TT-25L	MAP-1806	SB-40140TR	DT-15	MP-1	HH1/2-1.25
	15400R-4T							HH3/4-2.3
	15500R-6T							-
	151200R-14T							-
Fine Pitch	MSRS 15300R-6T	SB-60120TR	TT-25L	-	-	-	MP-1	HH1/2-1.25
	15400R-6T							HH3/4-2.3
	15500R-8T							-
	151200R-16T							-
Coarse Pitch	MSRS 15080R-4T(-M)	SB-60120TR	TT-25L	MAP-1806	SB-40140TR	DT-15	MP-1	HH12X35
	15100R-4T(-M)							-
	15315R-14T(-M)							-
Fine Pitch	MSRS 15080R-6T(-M)	SB-60120TR	TT-25L	-	-	-	MP-1	HH12X35
	15100R-6T(-M)							-
	15315R-16T(-M)							-

Coat Anti-seize Compound (MP-1) thinly on portion of taper and thread when insert is fixed

Applicable Inserts **D6**

- : U.S. Stock Standard
- : Made to Order / Quoted Item
- : World Express (Shipping: 7-10 Business Days)