

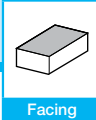

MSRS15 HEAVY MILLING



Facing

MSRS15 Face Mill (Inch Bore Dia.)

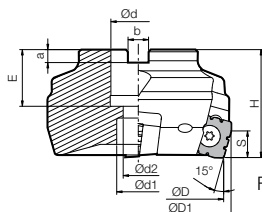
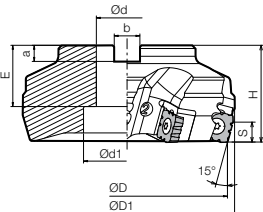
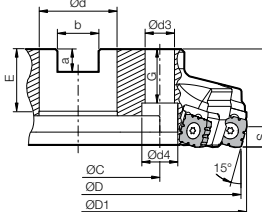
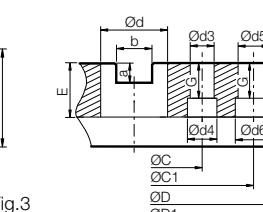

Rake Angle (°)		
Part Number	A.R.	R.R.
MSRS153000R...	+9°	-9°
MSRS154000R...	+9°	-5°
MSRS1512000R...	+9°	-5°
MSRS15080R...	+9°	-9°
MSRS15100R...	+9°	-5°
MSRS15315R...	+9°	-5°

(Coarse Pitch Shown)

Toolholder Dimensions (Bore Dia Ød: Inch)

Part Number	Stock	Unit	No. of Inserts	Dimensions																Drawing	Weight (kg)						
				ØD	ØD1	Ød	Ød1	Ød2	H	E	a	b	S	Ød3	Ød4	Ød5	Ød6	ØC	ØC1			ØG					
MSRS 153000R-4T	●	inch	4	3.00	3.27	1.000	0.87	0.551	1.97	0.75	0.31	0.375	-	-	-	-	-	-	-	-	Fig.1	1.3					
	●		4	4.00	4.27	1.250	1.38	0.40		0.500	Fig.2	2.0															
	●		6	5.00	5.27	1.500	2.13	0.40	0.625	Fig.2	3.6																
	●		8	6.00	6.27	2.000	2.68	0.47	0.750	0.47	Fig.2	5.0															
	●		10	8.00	8.27	2.500	-	2.48	1.25	0.53	1.000	0.675									1.045	4	-	1.25	Fig.3	7.7	
	●		12	10.00	10.27																				Fig.3	12.0	
	□		14	12.00	12.27	Fig.4	17.0																				
MSRS 153000R-6T	●	inch	6	3.00	3.27	1.000	0.87	0.551	1.97	0.75	0.31	0.375	-	-	-	-	-	-	-	-	-	Fig.1	1.3				
	●		6	4.00	4.27	1.250	1.38	0.40		0.500	Fig.2	1.9															
	●		8	5.00	5.27	1.500	2.13	0.40	0.625	Fig.2	3.5																
	●		10	6.00	6.27	2.000	2.68	0.47	0.750	Fig.2	4.9																
	●		12	8.00	8.27	2.500	-	2.48	1.25	0.53	1.000	0.675										1.045	4	-	1.25	Fig.3	7.6
	●		14	10.00	10.27																					Fig.3	11.9
	□		16	12.00	12.27	Fig.4	17.0																				
MSRS 15080R-4T	○	mm	4	80	87	1.000"	20	13	50	1.024"	0.236"	0.375"	-	-	-	-	-	-	-	-	-	Fig.1	1.3				
	○		4	100	107	1.250"	42	1.260"		0.315"	0.500"	Fig.2										2.0					
	○		6	125	132	1.500"	54	0.394"	0.625"	Fig.2	3.6																
	○		8	160	167	2.000"	68	0.433"	0.750"	12	Fig.2	5.0															
	○		10	200	207	1.875"	-	60	1.496"	0.551"	1.000"	18										26	101.6	32	Fig.3	7.7	
	○		12	250	257																				Fig.3	12.0	
	○		14	315	322	Fig.4	17.0																				
MSRS 15080R-6T	○	mm	6	80	87	1.000"	20	13	50	1.024"	0.236"	0.375"	-	-	-	-	-	-	-	-	-	Fig.1	1.3				
	○		6	100	107	1.250"	42	1.260"		0.315"	0.500"	Fig.2										1.9					
	○		8	125	132	1.500"	54	0.394"	0.625"	Fig.2	3.5																
	○		10	160	167	2.000"	68	0.433"	0.750"	12	Fig.2	4.9															
	○		12	200	207	1.875"	-	60	1.496"	0.551"	1.000"	18										26	101.6	32	Fig.3	7.6	
	○		14	250	257																				Fig.3	11.9	
	□		16	315	322	Fig.4	17.0																				

- Mounting bolts (HH12X35) are included in MSRS15080R-OT. (HH1/2-1.25) are included with MSRS153000R-OT.
- Cartridge is included in the coarse pitch cutters, but no Cartridge in the fine pitch.

Applicable Inserts **D6**