

MSO45-S with Cylindrical Shank (High Rake)

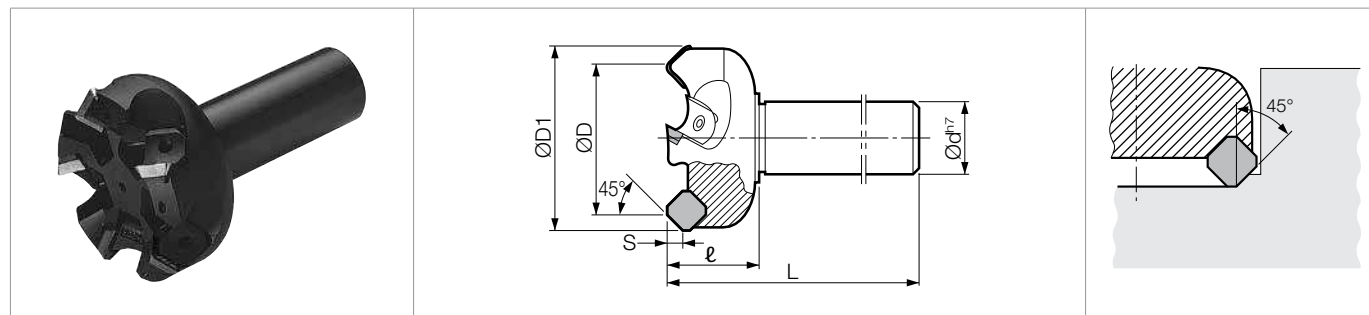

Toolholder Dimensions

Part Number	Stock	No. of Inserts	Dimensions (mm)						Rake Angle (°)		Spare Parts				
			ØD	ØD1	Ød	L	ℓ	S	A.R.	R.R.	Shim	Shim Clamp Screw	Clamp	Clamp Screw	Wrench
MSO 4550-S	○	4	50	66	32	120	40	7.1	+27°	-8°					
4563-S	○	5	63	79	32	120	40	7.1							
4580-S	○	5	80	96	32	120	40	7.1							

MSO45 Face Mill (High Rake)

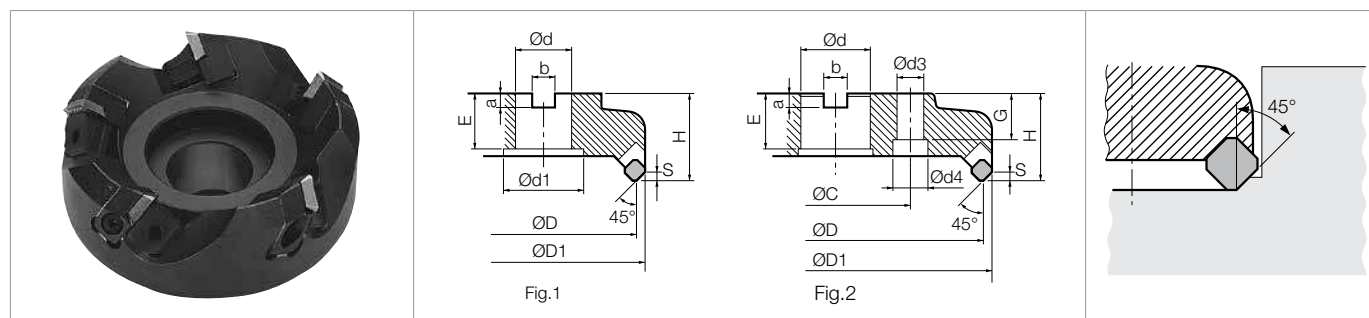

Toolholder Dimensions

Part Number	Stock	No. of Inserts	Dimensions (mm)													Rake Angle (°)		Drawing	Weight (kg)	
			ØD	ØD1	Ød	Ød1	Ød2	Ød3	Ød4	ØC	H	E	G	a	b	S	A.R.			R.R.
MSO 45100R	○	5	100	114.8	31.750	48	-	-	-	-	60	32	-	8	12.7	7.1	+27°	-8°	Fig.1	2.5
45125R	○	6	125	140.0	38.100	58	-	-	-	-	60	38	-	10	15.9	7.1			Fig.1	3.7
45160R	○	8	160	174.5	50.800	68	-	-	-	-	60	38	-	11	19.0	7.1			Fig.1	5.4
45200R	○	10	200	214.5	47.625	-	-	18	26	101.6	60	38	32	14	25.4	7.1			Fig.2	8.4

Spare Parts

Part Number	Spare Parts				
	① Cartridge	② Cartridge Clamp Screw	③ Clamp	④ Clamp Screw	Wrench
MSO 45...R					
	LSO-445R	HH4X16	CH-20R	TH8X15	TH-4

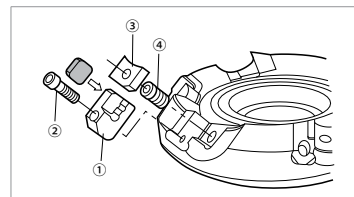

Applicable Inserts

Part Number	Applicable Inserts B10		Applicable PCD Inserts B26
MSO 45...	SOKR 13T3AXEN-J	SOKN 13T3AXTN 13T3AXFN	SOKN 13T3AXFN-NE

Recommended Cutting Conditions **C23**