

TERMS AND ANGLES OF TOOLHOLDER

Terms and Angles of Milling Cutters

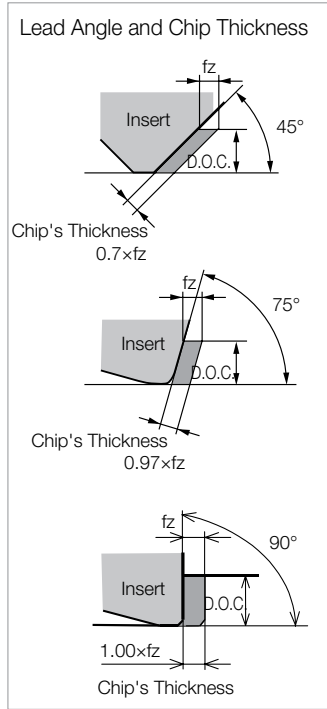
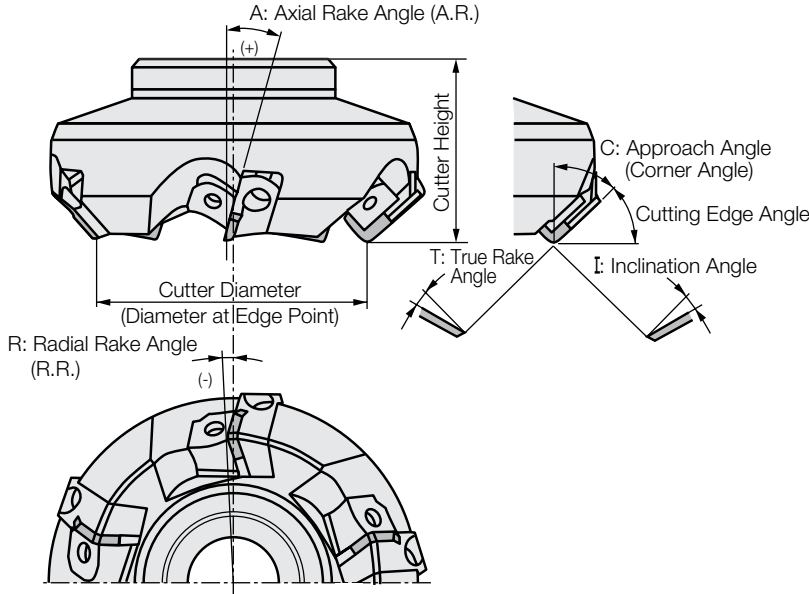

Function of Tool Angles

Symbol	Name	Function	Effect
A	Axial Rake Angle (A.R.)	Controls chip flow direction and cutting force	When it is positive ... Good cutting performance and less chip welding
R	Radial Rake Angle (R.R.)	Controls chip flow direction and cutting force	When it is negative ... Good chip evacuation
C	Approach Angle	Controls chip thickness and chip flow direction	When it is large ... Thinner chip thickness Lower cutting load
T	True Rake Angle	Actual rake angle	When it is positive ... Good cutting performance and less chip welding, but lower edge strength When it is negative ... Higher edge strength but easier to weld
I	Inclination Angle	Controls chip flow direction	When it is positive ... Good chip evacuation Less cutting force Lower edge stability of the corner part

True Rake Calculation Formula : $\tan T = \tan R \times \cos C + \tan A \times \sin C$

Cutting Edge Inclination Angle Formula : $\tan I = \tan A \times \cos C - \tan R \times \sin C$

Number of Inserts (Z)

1) If there is one stage

If the number of stage is one, it is not indicated on the catalog. Please use "No. of inserts" of the catalogue for "Z" of the formula to calculate cutting conditions.

2) If the number of stages is more than two

If the number of stages is more than two, it is indicated on the catalog. Please use "No. of Flutes" of the catalogue for "Z" of the formula to calculate cutting conditions.

MECX End Mill

Toolholder Dimensions

Description	Std.	No. of Inserts	φD
MECX 08-S10-07-1T	●	8	
14-S12-07-2T	●	14	
17-S16-07-3T	●	17	
18-S19-07-3T	●	18	
20-S16-07-4T	●	20	

$$fz = \frac{V_f}{Z \times n} \Rightarrow V_f = fz \times Z \times n$$

MSR

Toolholder Dimensions (Bore id: Inch)

Description	Std.	No. of Inserts	No. of Flutes	φD	φD1	φd
MSR 063R-1	●	1	1	63	50	25.4
063R-2	●	2	2	63	50	25.4
080R-1	●	4	1	80	55	25.4
080R-2	●	8	2	80	70	31.75
090R-4	●	16	4	90	55	25.4

$$fz = \frac{V_f}{Z \times n} \Rightarrow V_f = fz \times Z \times n$$