

# CAT40

## Face Mill Toolholders

- Made from 8620 Alloy Steel
- Concentricity is less than .0002 at face and arbor
- All critical surfaces are precision ground
- Case hardened to 54-58 RC
- Case depth is .03-.04
- Balanced to G2.5 @ 20,000 rpm
- Rear thread for pull stud is 5/8-11
- Coolant through capable

### CAT40 Face Mill Holders

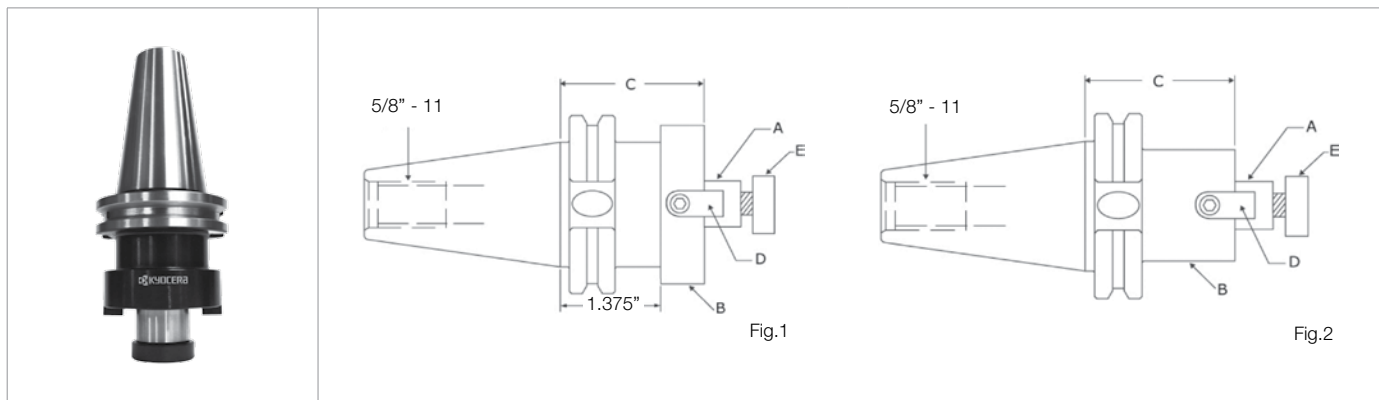

### CAT40 Holder Dimensions

Part Number	Stock	Dimensions (in)					
		Arbor Dia. (A)	O.D. (B)	Gage Length (C)	Key Width (D)	Screw (E)	Drawing
KYO-CAT40- FM.75-2.0	●	0.750	1.750	2.000	5/16	3/8-24	2
FM1.0-2.0	●	1.000	2.180	2.000	3/8	1/2-20	1
FM1.25-2.0	●	1.250	2.440	2.000	1/2	5/8-18	1
FM1.5-2.0	●	1.500	2.520	2.000	5/8	3/4-16	1