

API Ring Groover

Kyocera is the only choice for economical ring groovers. Featuring an integral shank for maximum rigidity, Kyocera's API Ring Groovers are the most versatile ring grooving tools on the market.

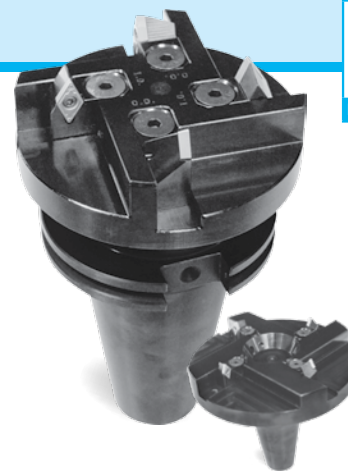

ADVANTAGES

- Create ring grooves per API Spec 6A for BX, R, and RX style grooves
- Roughout and finish of inlay of API Ring Grooves
- Replaceable cartridges allow a single cutter body to produce multiple size API grooves
- Integral shank, multiple sizes and styles available

3 Line Items, Ordered Separately

- ① Cartridge Set (2 OD & 2 ID)
- ② Body (Ex. API-RG1-CV50)
- ③ Inserts (Ex. VCMT333, DCMT3252, etc.)

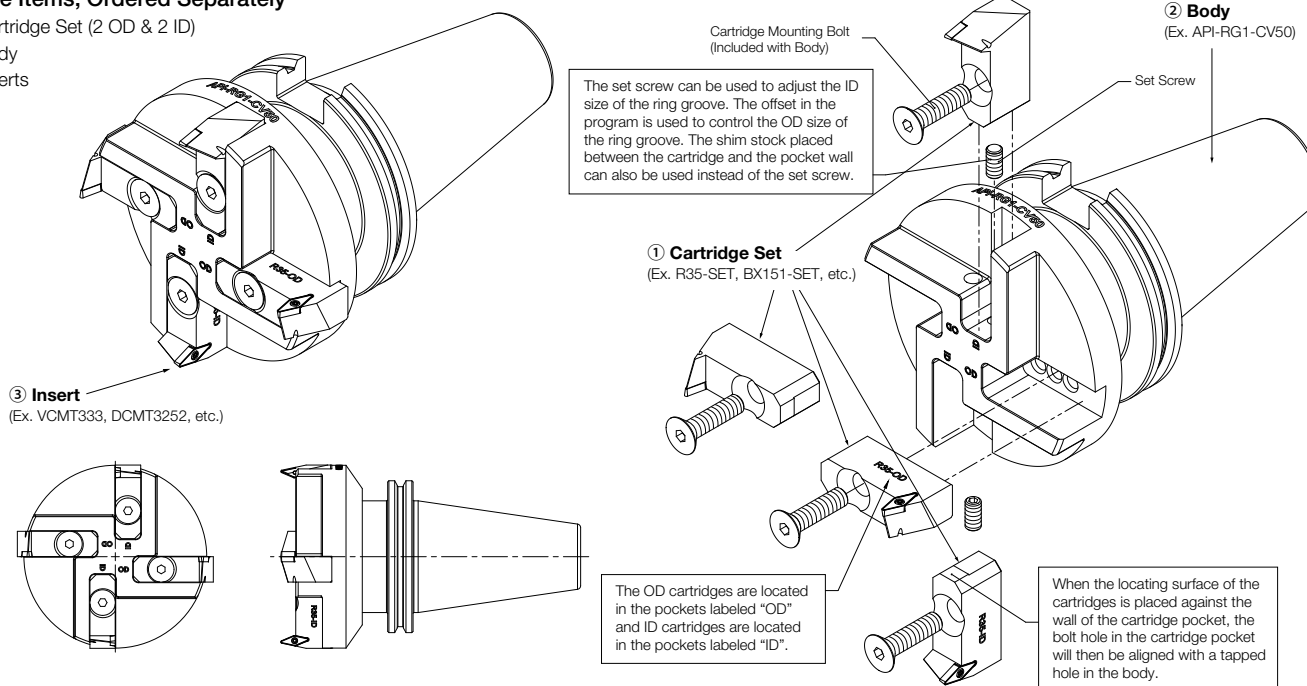

API Ring Groover Dimensions

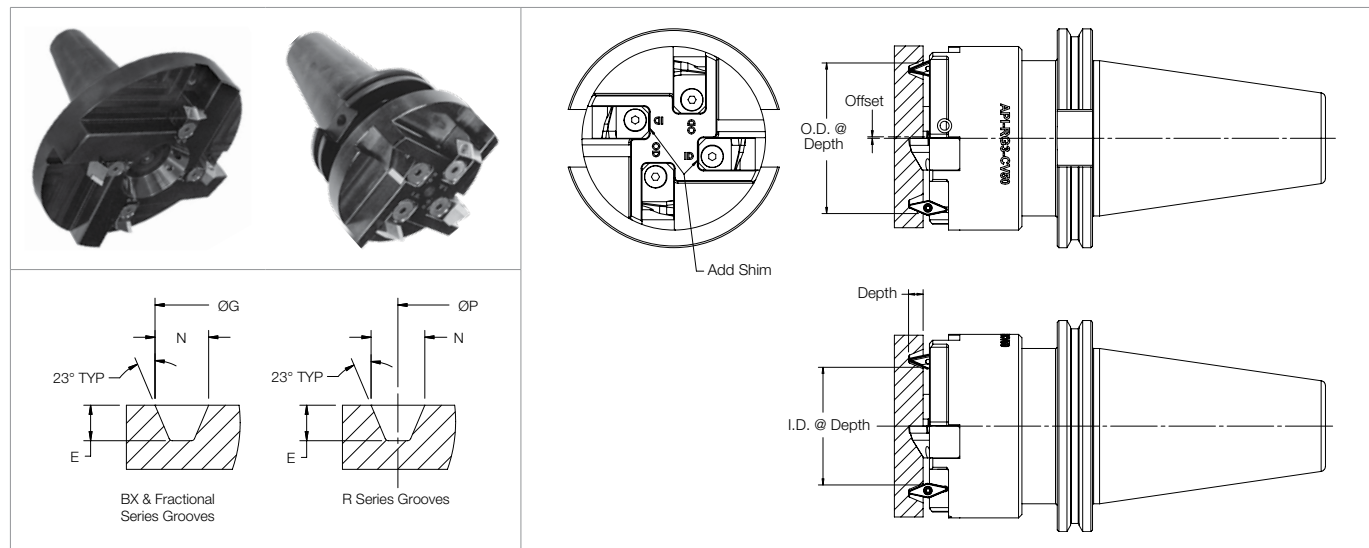

See Dimension Table [K3](#)